

SMD Communication Crystal

Low profile SMD AT-cut quartz crystal in a ceramic package with a 2.5 mm x 2.0 mm foot print.

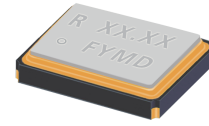

Product description

Miniature low profile AT-cut quartz crystal. True SMD style, ceramic package with nickel plated lid, seam welded. The product is supplied on tape and reel.

Applications

- Feature phone
- GPS

Features

- Excellent shock and vibration performance
- Low aging

Specifications

1.0 SPECIFICATION REFERENCE

Line	Parameter	Description
1.1	Model description	RSX-10
1.2	RoHS compliant	Yes
1.3	Reference number	
1.4	Rakon part number	

2.0 FREQUENCY CHARACTERISTICS

Line	Parameter	Test Condition	Value	Unit
2.1	Frequency		16.368 to 52	MHz
2.2	Calibration tolerance	Frequency at 25°C ±2°C and specified load capacitance	±10 to 50	ppm
2.3	Reflow shift	Two consecutive reflows as per attached profile after 4 hours recovery at 25°C	±1 max	ppm
2.4	Frequency stability over temperature	Referenced to frequency reading at 25°C and the specified load capacitance	±10 to 50	ppm
2.5	Temperature range	Operating temperature	-40 to 85	°C
2.6	Frequency perturbations	Peak-to-peak deviation from the frequency versus temperature curve fit 5th order. Minimum of 1 frequency reading every 3°C over operating temperature range	1 max	ppm
2.7	Static temperature hysteresis	Frequency change after reciprocal temperature ramped over the operating range. Frequency measured before and after at 25°C	±0.4 max	ppm
2.8	Long term stability	Frequency drift over 1 year at 25°C	±1 max	ppm
2.9	g sensitivity	Gamma vector of all three axes from 30 Hz to 1500 Hz	2 max	ppb/g

3.0 ELECTRICAL

Line	Parameter	Test Condition	Value	Unit
3.1	Load capacitance (CL)	Frequency is calibrated at room temperature.	5 to 50	pF
3.2	Shunt capacitance (C0)	Operating specification	0.5 to 3	pF
3.3	Drive level	Operating specification	50 max	µW
3.4	Equivalent series resistance (ESR)		60 max	Ω
3.5	Insulation resistance (IR)	100V ±15V at 25°C	500 min	MΩ

4.0 ENVIRONMENTAL

Line	Parameter	Description
4.1	Shock	Half sine-wave acceleration of 100g peak amplitude for 11 ms duration, 3 cycles in each plane
4.2	Humidity	After 48 hours at 85°C 85% relative humidity non-condensing
4.3	Thermal shock	Exposed at -40°C for 30 minutes then to 85°C for 30 minutes constantly for a period of 5 days
4.4	Vibration	10g RMS 30 Hz to 1500 Hz duration for 6 hours
4.5	Storage temperature	-55 to 105°C

5.0 MANUFACTURING INFORMATION

Line	Parameter	Description
5.1	Washing	Able to withstand aqueous washing process
5.2	Reflow	Able to withstand reflow process
5.3	Packaging description	Tape and Reel. 3000 pcs per reel standard. Refer to drawing for details

6.0 MARKING

Line	Parameter	Description
6.1	Type	Laser engraved
6.2	Line 1	R and frequency in MHz [XX.XX]
6.3	Line 2	Pin 1 and Date code

Drawing Name: RSX-10 Model Drawing

MODEL OUTLINE

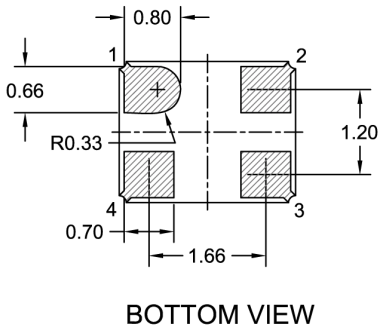
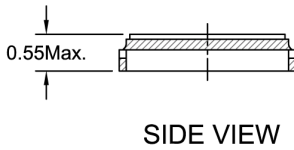
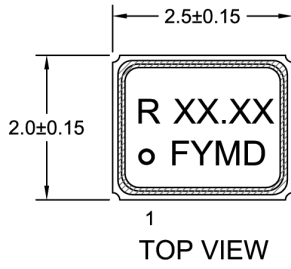

MARKING EXAMPLE

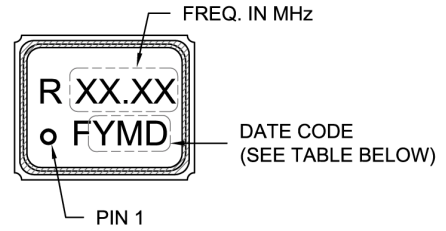

PIN CONNECTIONS	
1	CRYSTAL
2	GND
3	CRYSTAL
4	GND

RECOMMENDED PAD LAYOUT - TOP VIEW

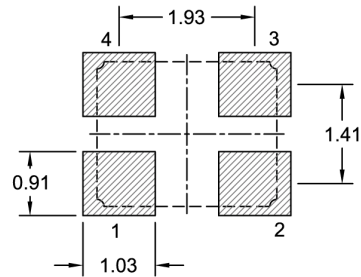

Y - Year Code

Code	Year	Code	Year
A	2010	N	2023
B	2011	O	2024
C	2012	P	2025
D	2013	Q	2026
E	2014	R	2027
F	2015	S	2028
G	2016	T	2029
H	2017	U	2030
I	2018	V	2031
J	2019	W	2032
K	2020	X	2033
L	2021	Y	2034
M	2022	Z	2035

M - Month Code

Code	Month
1	Jan
2	Feb
3	Mar
4	Apr
5	May
6	Jun
7	Jul
8	Aug
9	Sep
A	Oct
B	Nov
C	Dec

D - Day Code

Code	Day	Code	Day	Code	Day
1	1	E	14	R	27
2	2	F	15	S	28
3	3	G	16	T	29
4	4	H	17	U	30
5	5	I	18	V	31
6	6	J	19		
7	7	K	20		
8	8	L	21		
9	9	M	22		
A	10	N	23		
B	11	O	24		
C	12	P	25		
D	13	Q	26		

TITLE: RSX-10 MODEL

RELATED DRAWINGS:

FILENAME: CAT450

REVISION: E

DATE: 12-Aug-11

SCALE: 10 : 1

Millimetres

TOLERANCES:

XX =

X.X =

X.XX = ±0.10

X.XXX =

X° =

Hole =

rakon

© 2009 Rakon Limited

Drawing Name: 2520 Series Tape & Reel

TAPE DETAIL (Scale 5 : 1)

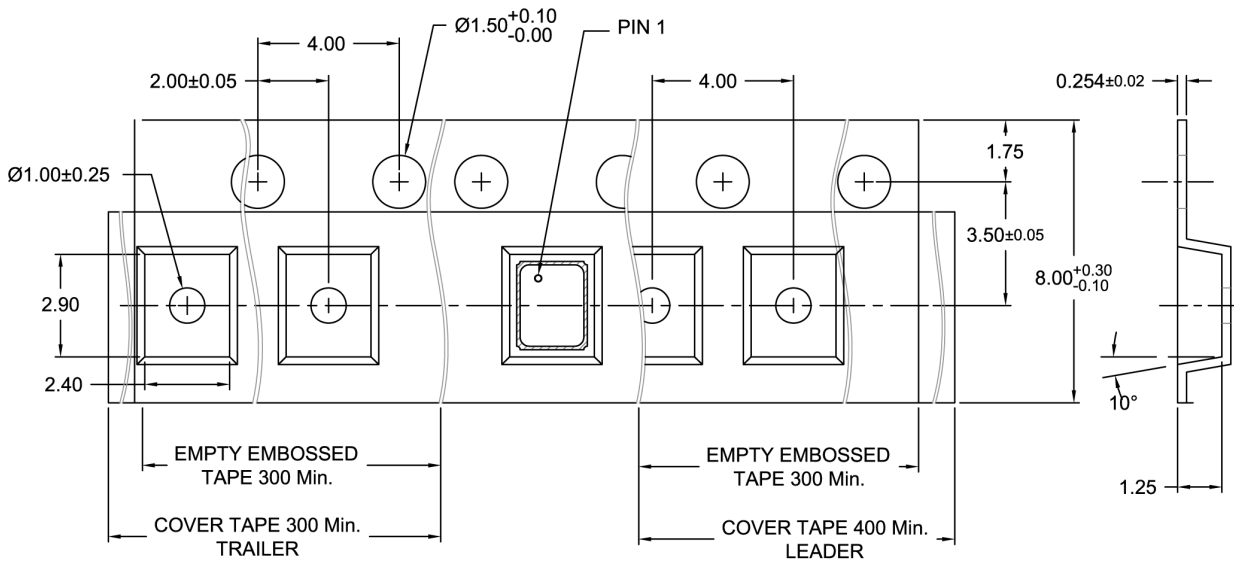

REEL DETAIL (Scale 1 : 2.5)

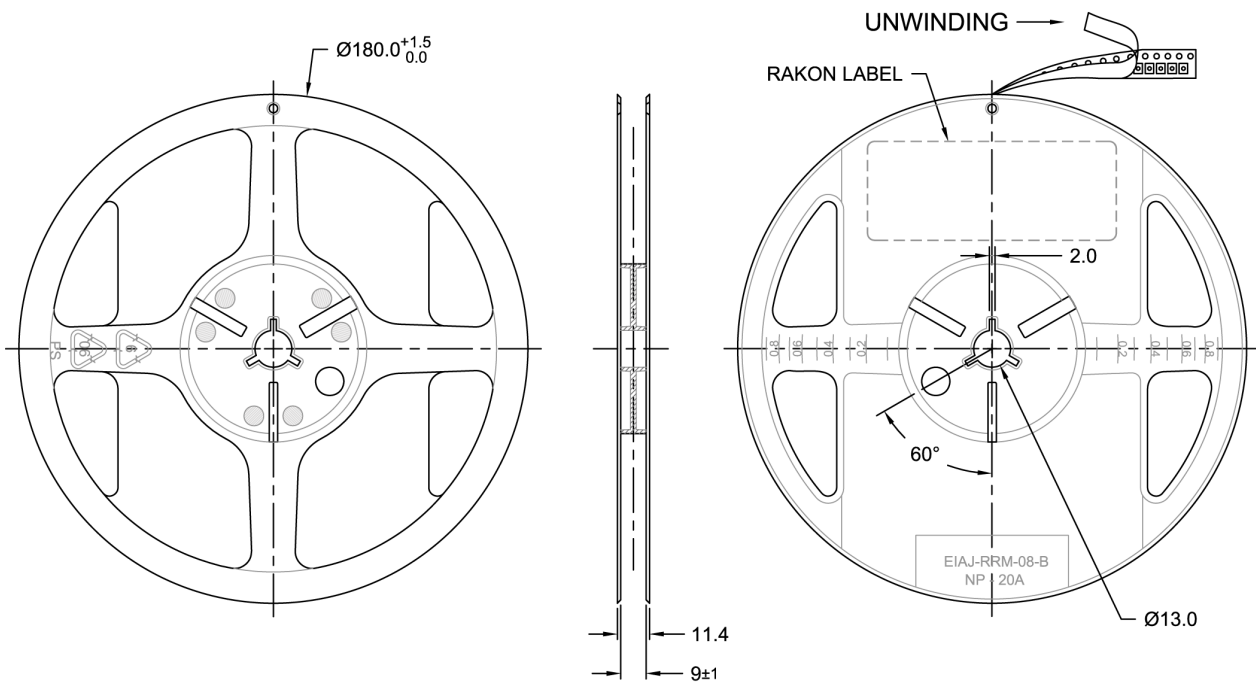

TITLE: 2520 SERIES CRYSTAL TAPE & REEL

RELATED DRAWINGS:

FILENAME: CAT492

REVISION: C

DATE: 26-Aug-11

SCALE: 5 : 1

Millimetres

TOLERANCES:

XX =

X.X = ± 0.2

X.XX = ± 0.10

X.XXX =

X° =

Hole =

rakon

© 2009 Rakon Limited

Drawing Name: RSX/RGX Crystals Pb-free Reflow

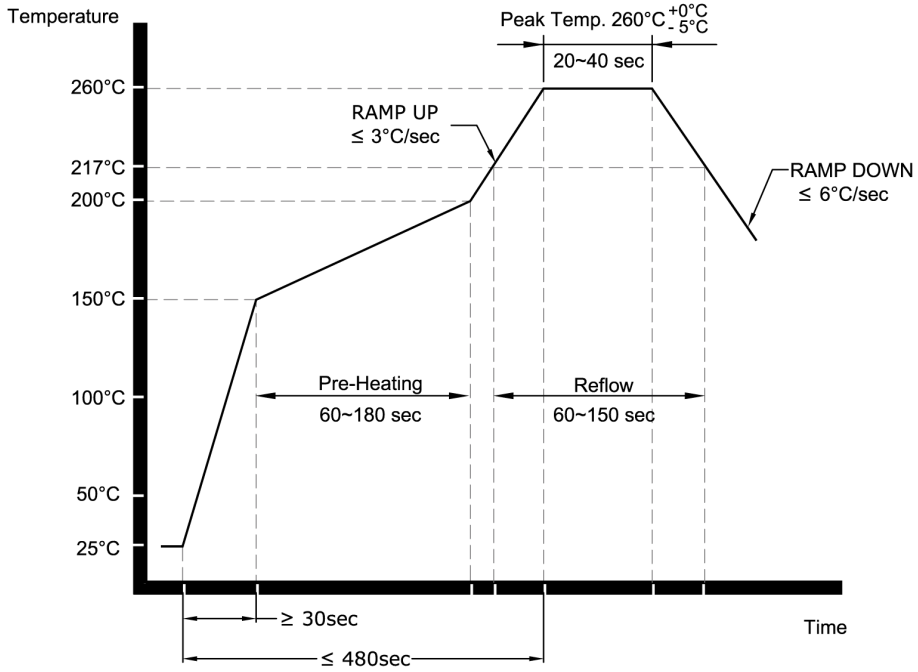

NOTE:

The product has been tested to withstand the Reflow Profile shown. The Reflow Profile used to solder Rakon RSX/RGX crystals are determined by the solder paste Manufacturer's specification. It is recommended that the Reflow Profile used does not exceed the one shown above.

TITLE: RSX/RGX CRYSTAL Pb-FREE REFLOW

FILENAME: CAT353

RELATED DRAWINGS:

REVISION: B

DATE: 01-Feb-07

SCALE: NTS

Millimetres



© 2009 Rakon Limited