

### General Description

The ICS840022I-02 is a Gigabit Ethernet Clock Generator. The ICS840022I-02 uses a 25MHz crystal to synthesize 125MHz or 62.5MHz. The ICS840022I-02 has excellent phase jitter performance, over the 12kHz – 20MHz integration range. The ICS840022I-02 is packaged in a small 16-pin VFQFN, making it ideal for use in systems with limited board space.

### Features

- One LVCMOS/LVTTL outputs, 20Ω output impedance
- Crystal oscillator interface designed for 25MHz, 18pF parallel resonant crystal
- Output frequencies: 125MHz or 62.5MHz
- RMS phase jitter at 125MHz using a 25MHz crystal (12kHz - 20MHz): 0.57ps (typical)
- Supply modes:  
Core/Output  
3.3V/3.3V  
3.3V/2.5V  
2.5V/2.5V
- -40°C to 85°C ambient operating temperature
- Available in lead-free (RoHS 6) package

### Function Table

Inputs	
FREQ_SEL	Output Frequency Range (with a 25MHz crystal)
0	125MHz
1	62.5MHz

### Block Diagram

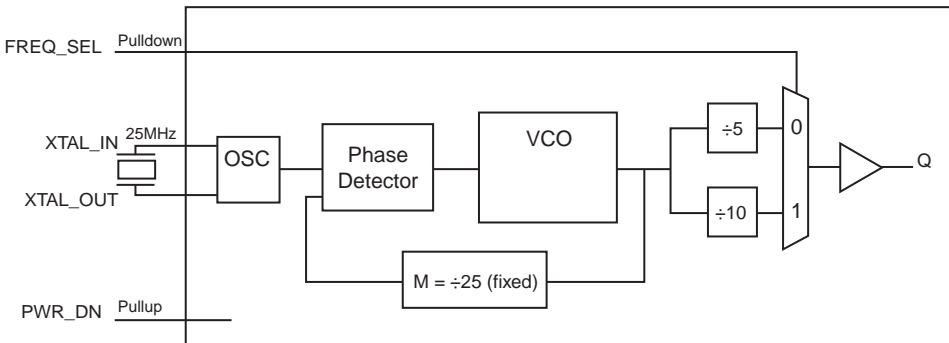

### Pin Assignment

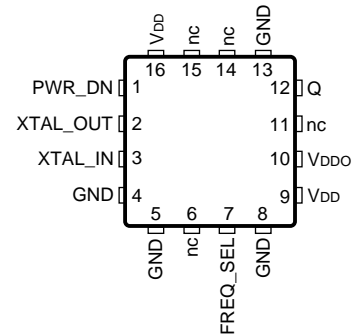

**ICS840022I-02**  
**16 Lead VFQFN**  
**Top View**

**Table 1. Pin Descriptions**

Number	Name	Type		Description
1	PWR_DN	Input	Pullup	Output state control pin. See Table 3. LVCMOS/LVTTL interface levels.
2, 3	XTAL_OUT, XTAL_IN	Input		Crystal oscillator interface. XTAL_IN is the input. XTAL_OUT is the output.
4, 5, 8, 13	GND	Power		Power supply ground.
6, 11, 14, 15	nc	Unused		No connect.
7	FREQ_SEL	Input	Pulldown	Frequency select pin. LVCMOS/LVTTL interface levels.
9, 16	V <sub>DD</sub>	Power		Power supply pins.
10	V <sub>DDO</sub>	Power		Output supply pin.
12	Q	Output		Single-ended clock output. 20Ω typical output impedance. LVCMOS/LVTTL interface levels.

NOTE: Pullup and Pulldown refer to internal input resistors. See Table 2, *Pin Characteristics*, for typical values.

**Table 2. Pin Characteristics**

Symbol	Parameter	Test Conditions	Minimum	Typical	Maximum	Units
C <sub>IN</sub>	Input Capacitance			4		pF
C <sub>PD</sub>	Power Dissipation Capacitance	V <sub>DD</sub> , V <sub>DDO</sub> = 3.465V or 2.625V		10		pF
R <sub>PULLUP</sub>	Input Pullup Resistor			51		kΩ
R <sub>PULLDOWN</sub>	Input Pulldown Resistor			51		kΩ
R <sub>OUT</sub>	Output Impedance			20		Ω

## Function Table

**Table 3. PWR\_DN Function Table**

PWR_DN Input	Description
0	Output in High-Impedance
1	Output in normal operation

## Absolute Maximum Ratings

NOTE: Stresses beyond those listed under *Absolute Maximum Ratings* may cause permanent damage to the device. These ratings are stress specifications only. Functional operation of product at these conditions or any conditions beyond those listed in the *DC Characteristics* or *AC Characteristics* is not implied. Exposure to absolute maximum rating conditions for extended periods may affect product reliability.

Item	Rating
Supply Voltage, $V_{DD}$	4.6V
Inputs, $V_I$	-0.5V to $V_{DD} + 0.5V$
Outputs, $V_O$	-0.5V to $V_{DD} + 0.5V$
Package Thermal Impedance, $\theta_{JA}$	74.9°C/W (0 mps)
Storage Temperature, $T_{STG}$	-65°C to 150°C

## DC Electrical Characteristics

**Table 4A. Power Supply DC Characteristics,  $V_{DD} = V_{DDO} = 3.3V \pm 5\%$ ,  $T_A = -40^\circ\text{C}$  to  $85^\circ\text{C}$**

Symbol	Parameter	Test Conditions	Minimum	Typical	Maximum	Units
$V_{DD}$	Power Supply Voltage		3.135	3.3	3.465	V
$V_{DDO}$	Output Supply Voltage		3.135	3.3	3.465	V
$I_{DD}$	Power Supply Current	PWR_DN = 1			77	mA
		PWR_DN = 0			<1	mA
$I_{DDO}$	Output Supply Current				12	mA

**Table 4B. Power Supply DC Characteristics,  $V_{DD} = V_{DDO} = 2.5V \pm 5\%$ ,  $T_A = -40^\circ\text{C}$  to  $85^\circ\text{C}$**

Symbol	Parameter	Test Conditions	Minimum	Typical	Maximum	Units
$V_{DD}$	Power Supply Voltage		2.375	2.5	2.625	V
$V_{DDO}$	Output Supply Voltage		2.375	2.5	2.625	V
$I_{DD}$	Power Supply Current	PWR_DN = 1			68	mA
		PWR_DN = 0			<1	mA
$I_{DDO}$	Output Supply Current				10	mA

**Table 4C. Power Supply DC Characteristics,  $V_{DD} = 3.3V \pm 5\%$ ,  $V_{DDO} = 2.5V \pm 5\%$ ,  $T_A = -40^\circ\text{C}$  to  $85^\circ\text{C}$**

Symbol	Parameter	Test Conditions	Minimum	Typical	Maximum	Units
$V_{DD}$	Power Supply Voltage		3.135	3.3	3.465	V
$V_{DDO}$	Output Supply Voltage		2.375	2.5	2.625	V
$I_{DD}$	Power Supply Current	PWR_DN = 1			77	mA
		PWR_DN = 0			<1	mA
$I_{DDO}$	Output Supply Current				10	mA

**Table 4D. LVCMOS/LVTTL DC Characteristics,  $T_A = -40^{\circ}\text{C}$  to  $85^{\circ}\text{C}$** 

Symbol	Parameter	Test Conditions	Minimum	Typical	Maximum	Units
$V_{IH}$	Input High Voltage	$V_{DD} = 3.465\text{V}$	2		$V_{DD} + 0.3$	V
		$V_{DD} = 2.625\text{V}$	1.7		$V_{DD} + 0.3$	V
$V_{IL}$	Input Low Voltage	$V_{DD} = 3.465\text{V}$	-0.3		0.8	V
		$V_{DD} = 2.625\text{V}$	-0.3		0.7	V
$I_{IH}$	Input High Current	FREQ_SEL $V_{DD} = V_{IN} = 3.465\text{V}$ or $2.625\text{V}$			150	$\mu\text{A}$
		PWR_DN $V_{DD} = V_{IN} = 3.465\text{V}$ or $2.625\text{V}$			5	$\mu\text{A}$
$I_{IL}$	Input Low Current	FREQ_SEL $V_{DD} = 3.465\text{V}$ or $2.625\text{V}$ , $V_{IN} = 0\text{V}$	-5			$\mu\text{A}$
		PWR_DN $V_{DD} = 3.465\text{V}$ or $2.625\text{V}$ , $V_{IN} = 0\text{V}$	-150			$\mu\text{A}$
$V_{OH}$	Output High Voltage; NOTE 1	$V_{DDO} = 3.465\text{V}$	2.6			V
		$V_{DDO} = 2.625\text{V}$	1.8			V
$V_{OL}$	Output Low Voltage; NOTE 1	$V_{DDO} = 3.465\text{V}$ or $2.625\text{V}$			0.5	V

NOTE 1: Outputs terminated with  $50\Omega$  to  $V_{DDO}/2$ . See Parameter Measurement Information, Output Load Test Circuit diagrams.

**Table 5. Crystal Characteristics**

Parameter	Test Conditions	Minimum	Typical	Maximum	Units
Mode of Oscillation		Fundamental			
Frequency			25		MHz
Equivalent Series Resistance (ESR)				50	$\Omega$
Shunt Capacitance				7	pF

## AC Electrical Characteristics

**Table 6A. AC Characteristics,  $V_{DD} = V_{DDO} = 3.3V \pm 5\%$ ,  $T_A = -40^\circ\text{C}$  to  $85^\circ$**

Symbol	Parameter	Test Conditions	Minimum	Typical	Maximum	Units
$f_{OUT}$	Output Frequency	FREQ_SEL = 0		125		MHz
		FREQ_SEL = 1		62.5		MHz
$f_{jit}(\emptyset)$	RMS Phase Jitter, Random; NOTE 1	125MHz, Integration Range: 12kHz – 20MHz		0.57		ps
		62.5MHz, Integration Range: 12kHz – 10MHz		0.58		ps
$t_R / t_F$	Output Rise/Fall Time	20% to 80%	200		700	ps
odc	Output Duty Cycle		47		53	%

NOTE: Electrical parameters are guaranteed over the specified ambient operating temperature range, which is established when the device is mounted in a test socket with maintained transverse airflow greater than 500 lfpm. The device will meet specifications after thermal equilibrium has been reached under these conditions.

NOTE 1: Refer to Phase Noise Plot.

**Table 6B. AC Characteristics,  $V_{DD} = V_{DDO} = 2.5V \pm 5\%$ ,  $T_A = -40^\circ\text{C}$  to  $85^\circ$**

Symbol	Parameter	Test Conditions	Minimum	Typical	Maximum	Units
$f_{OUT}$	Output Frequency	FREQ_SEL = 0		125		MHz
		FREQ_SEL = 1		62.5		MHz
$f_{jit}(\emptyset)$	RMS Phase Jitter, Random; NOTE 1	125MHz, Integration Range: 12kHz – 20MHz		0.62		ps
		62.5MHz, Integration Range: 12kHz – 10MHz		0.58		ps
$t_R / t_F$	Output Rise/Fall Time	20% to 80%	200		700	ps
odc	Output Duty Cycle		47		53	%

NOTE: Electrical parameters are guaranteed over the specified ambient operating temperature range, which is established when the device is mounted in a test socket with maintained transverse airflow greater than 500 lfpm. The device will meet specifications after thermal equilibrium has been reached under these conditions.

NOTE 1: Refer to Phase Noise Plot.

**Table 6C. AC Characteristics,  $V_{DD} = 3.3V \pm 5\%$ ,  $V_{DDO} = 2.5V \pm 5\%$ ,  $T_A = -40^\circ\text{C}$  to  $85^\circ$**

Symbol	Parameter	Test Conditions	Minimum	Typical	Maximum	Units
$f_{OUT}$	Output Frequency	FREQ_SEL = 0		125		MHz
		FREQ_SEL = 1		62.5		MHz
$f_{jit}(\emptyset)$	RMS Phase Jitter, Random	125MHz, Integration Range: 12kHz – 20MHz		0.62		ps
		62.5MHz, Integration Range: 12kHz – 10MHz		0.58		ps
$t_R / t_F$	Output Rise/Fall Time	20% to 80%	200		750	ps
odc	Output Duty Cycle		47		53	%

NOTE: Electrical parameters are guaranteed over the specified ambient operating temperature range, which is established when the device is mounted in a test socket with maintained transverse airflow greater than 500 lfpm. The device will meet specifications after thermal equilibrium has been reached under these conditions.

### Typical Phase Noise at 62.5MHz (3.3V)

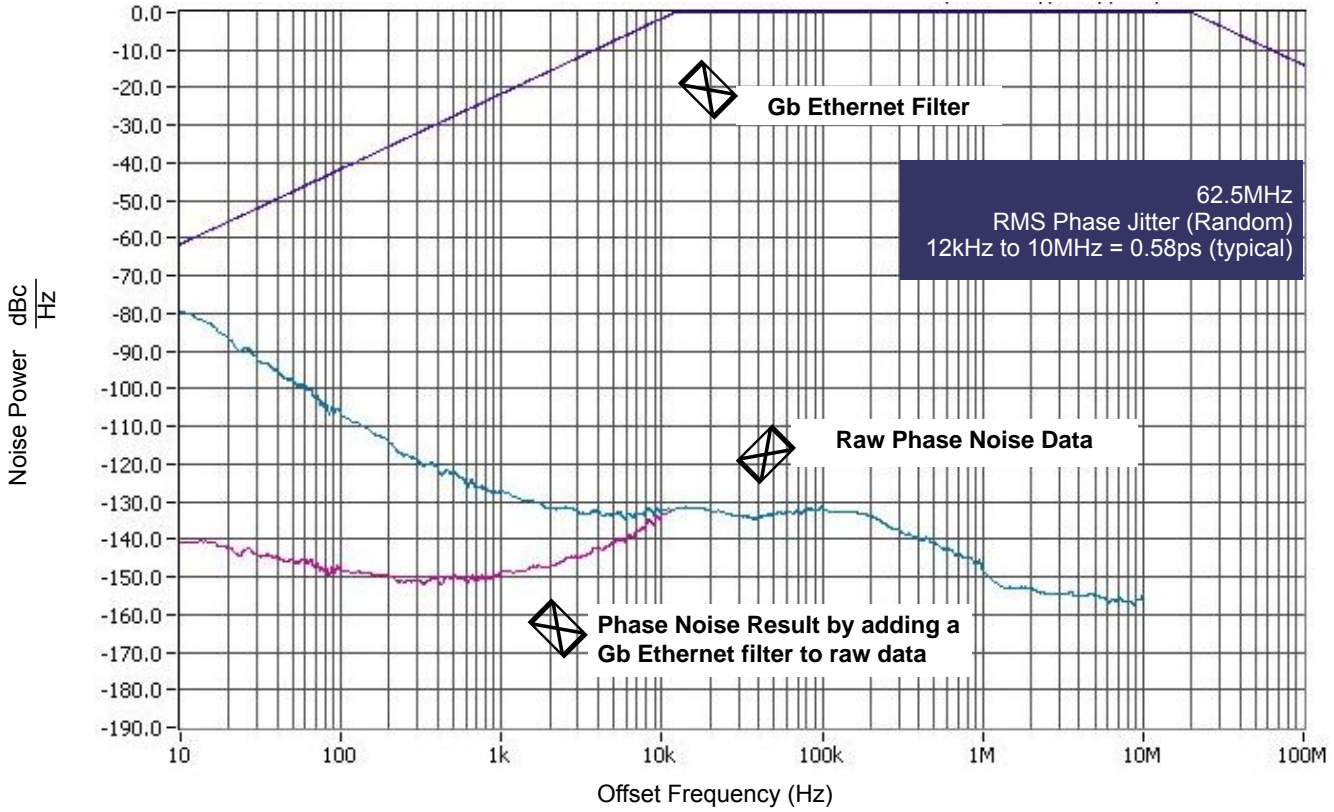

### Typical Phase Noise at 125MHz (3.3V)

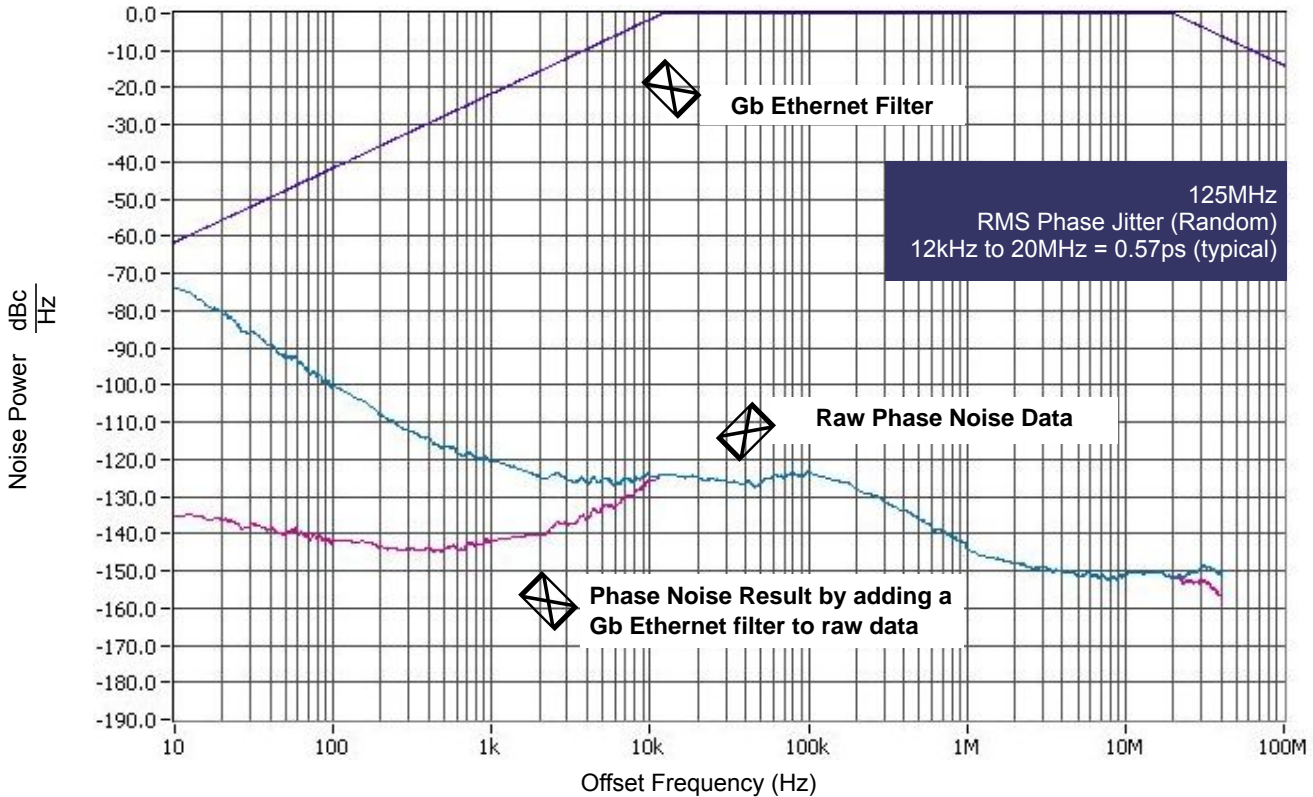

### Parameter Measurement Information

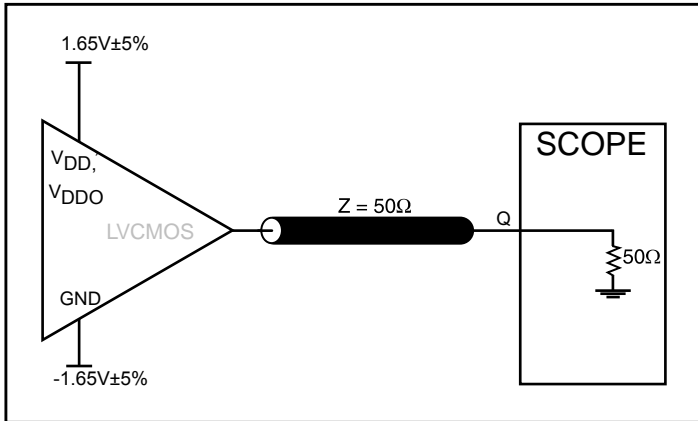

3.3V LVCMOS Output Load AC Test Circuit

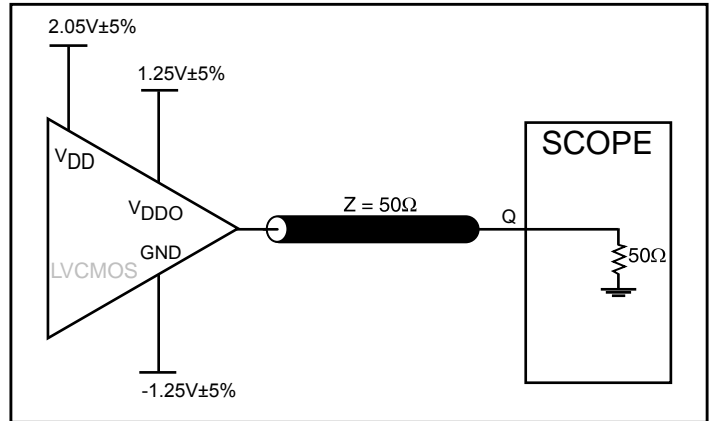

3.3V/2.5V LVCMOS Output Load AC Test Circuit

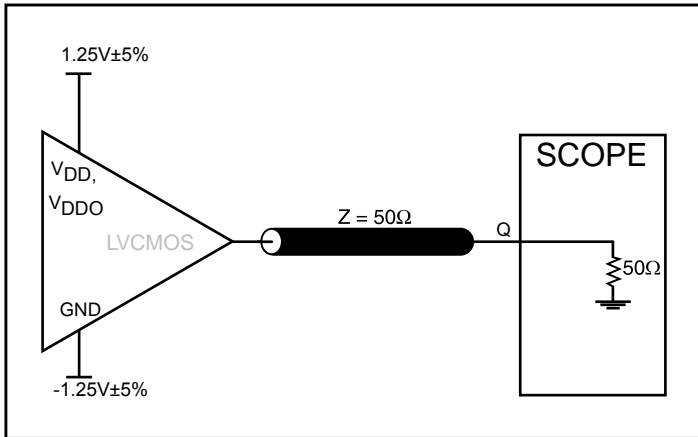

2.5V LVCMOS Output Load AC Test Circuit

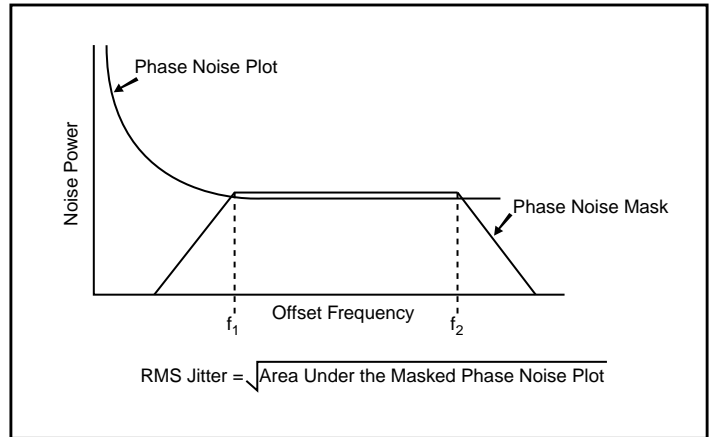

RMS Phase Jitter

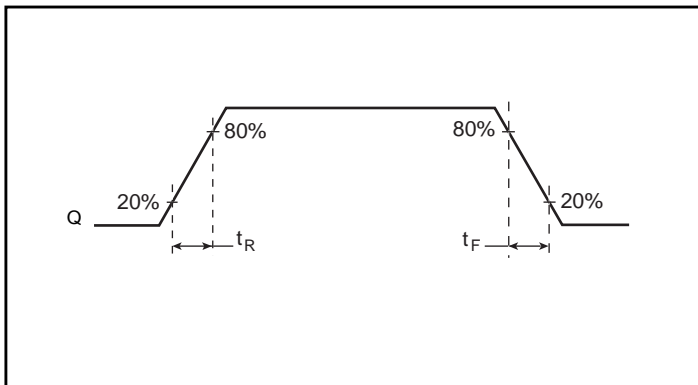

Output Rise/Fall Time

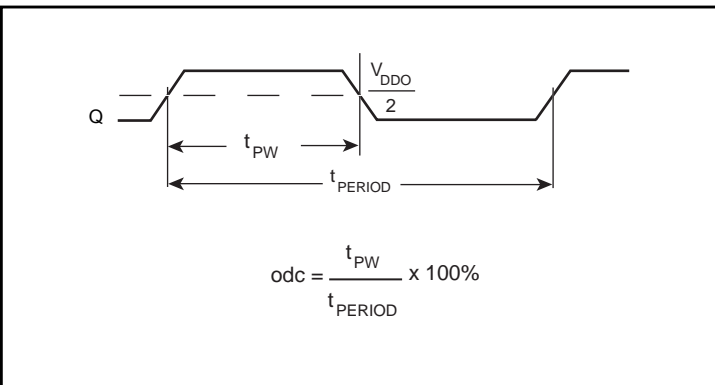

Output Duty Cycle/Pulse Width/Period

## Applications Information

### Crystal Input Interface

The ICS840022I-02 has been characterized with 18pF parallel resonant crystals. The capacitor values, C1 and C2, shown in *Figure 1* below were determined using a 25MHz, 18pF parallel resonant crystal and were chosen to minimize the ppm error. The optimum C1 and C2 values can be slightly adjusted for different board layouts.

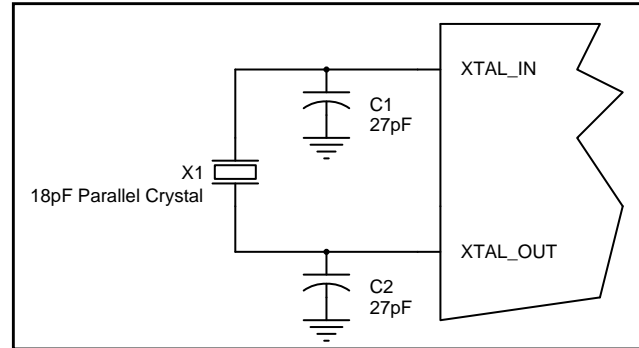
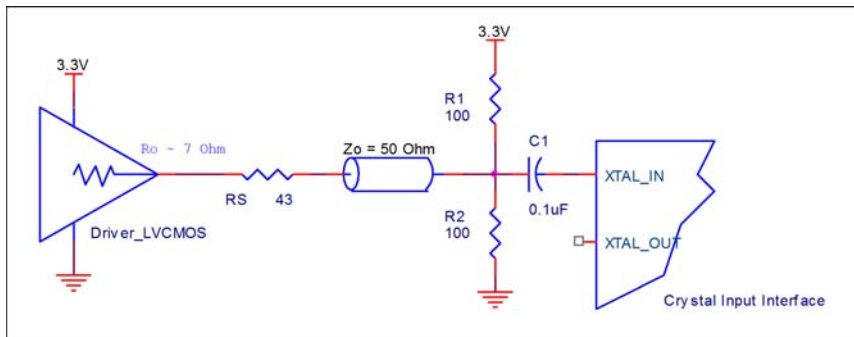

**Figure 2. Crystal Input Interface**

### Overdriving the XTAL Interface

The XTAL\_IN input can accept a single-ended LVCMOS signal through an AC coupling capacitor. A general interface diagram is shown in *Figure 2A*. The XTAL\_OUT pin can be left floating. The maximum amplitude of the input signal should not exceed 2V and the input edge rate can be as slow as 10ns. This configuration requires that the output impedance of the driver ( $R_o$ ) plus the series resistance ( $R_s$ ) equals the transmission line impedance. In addition,

matched termination at the crystal input will attenuate the signal in half. This can be done in one of two ways. First, R1 and R2 in parallel should equal the transmission line impedance. For most 50Ω applications, R1 and R2 can be 100Ω. This can also be accomplished by removing R1 and making R2 50Ω. By overdriving the crystal oscillator, the device will be functional, but note, the device performance is guaranteed by using a quartz crystal.



**Figure 2A. General Diagram for LVCMOS Driver to XTAL Input Interface**

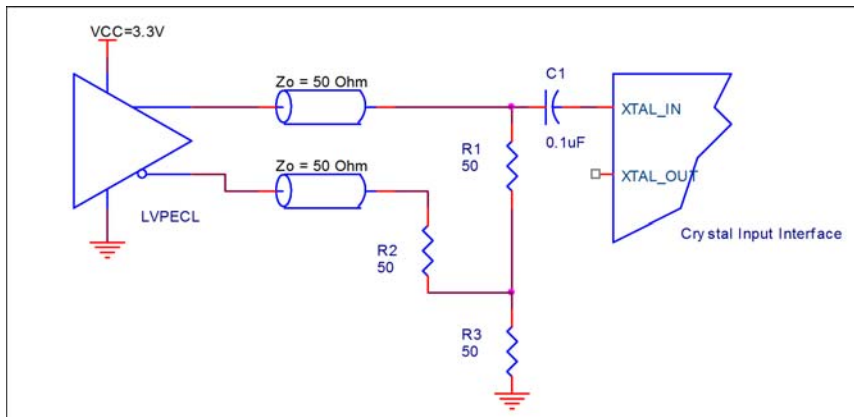

**Figure 2B. General Diagram for LVPECL Driver to XTAL Input Interface**



## Recommendations for Unused Input Pins

### Inputs:

#### LVCMOS Control Pins

The control pins have an internal pullup and pulldown; additional resistance is not required but can be added for additional protection. A 1k $\Omega$  resistor can be used.

### VFQFN EPAD Thermal Release Path

In order to maximize both the removal of heat from the package and the electrical performance, a land pattern must be incorporated on the Printed Circuit Board (PCB) within the footprint of the package corresponding to the exposed metal pad or exposed heat slug on the package, as shown in *Figure 3*. The solderable area on the PCB, as defined by the solder mask, should be at least the same size/shape as the exposed pad/slug area on the package to maximize the thermal/electrical performance. Sufficient clearance should be designed on the PCB between the outer edges of the land pattern and the inner edges of pad pattern for the leads to avoid any shorts.

While the land pattern on the PCB provides a means of heat transfer and electrical grounding from the package to the board through a solder joint, thermal vias are necessary to effectively conduct from the surface of the PCB to the ground plane(s). The land pattern must be connected to ground through these vias. The vias act as “heat pipes”. The number of vias (i.e. “heat pipes”) are application specific

and dependent upon the package power dissipation as well as electrical conductivity requirements. Thus, thermal and electrical analysis and/or testing are recommended to determine the minimum number needed. Maximum thermal and electrical performance is achieved when an array of vias is incorporated in the land pattern. It is recommended to use as many vias connected to ground as possible. It is also recommended that the via diameter should be 12 to 13mils (0.30 to 0.33mm) with 1oz copper via barrel plating. This is desirable to avoid any solder wicking inside the via during the soldering process which may result in voids in solder between the exposed pad/slug and the thermal land. Precautions should be taken to eliminate any solder voids between the exposed heat slug and the land pattern. Note: These recommendations are to be used as a guideline only. For further information, please refer to the Application Note on the Surface Mount Assembly of Amkor’s Thermally/Electrically Enhance Leadframe Base Package, Amkor Technology.

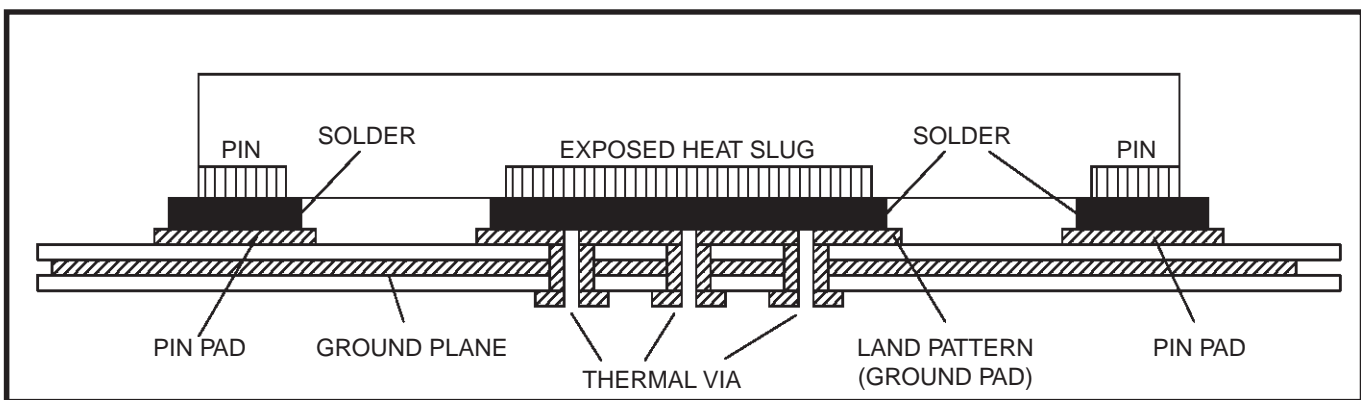

Figure 3. P.C. Assembly for Exposed Pad Thermal Release Path – Side View (drawing not to scale)

## Reliability Information

Table 7.  $\theta_{JA}$  vs. Air Flow Table for a 16 Lead VFQFN

$\theta_{JA}$ at 0 Air Flow			
Meters per Second	0	1	2.5
Multi-Layer PCB, JEDEC Standard Test Boards	74.9°C/W	65.5°C/W	58.8°C/W

## Transistor Count

The transistor count for ICS840022I-02 is: 1760

# Package Outline Drawings (Sheet 1)

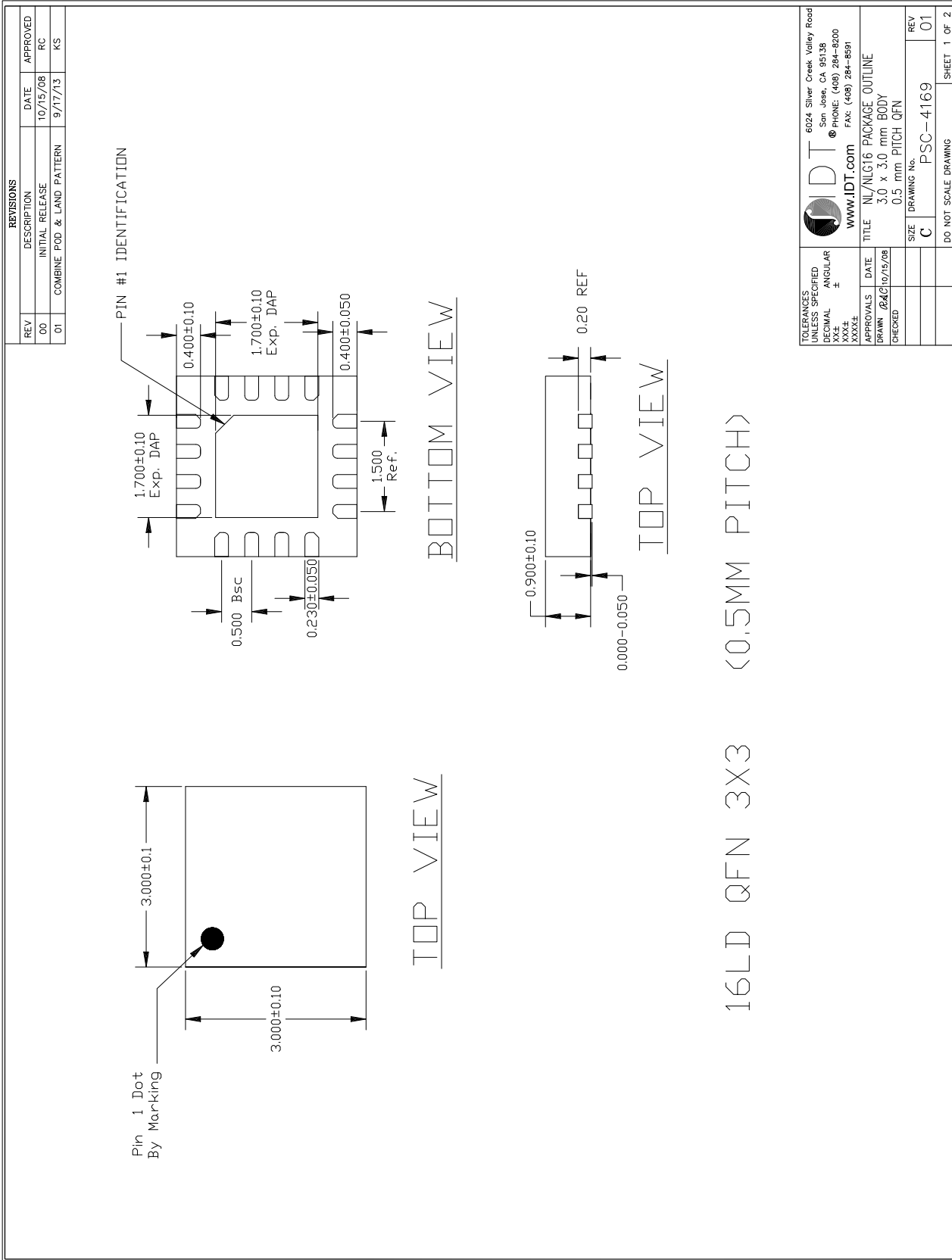

# Package Outline Drawings (Sheet 2)

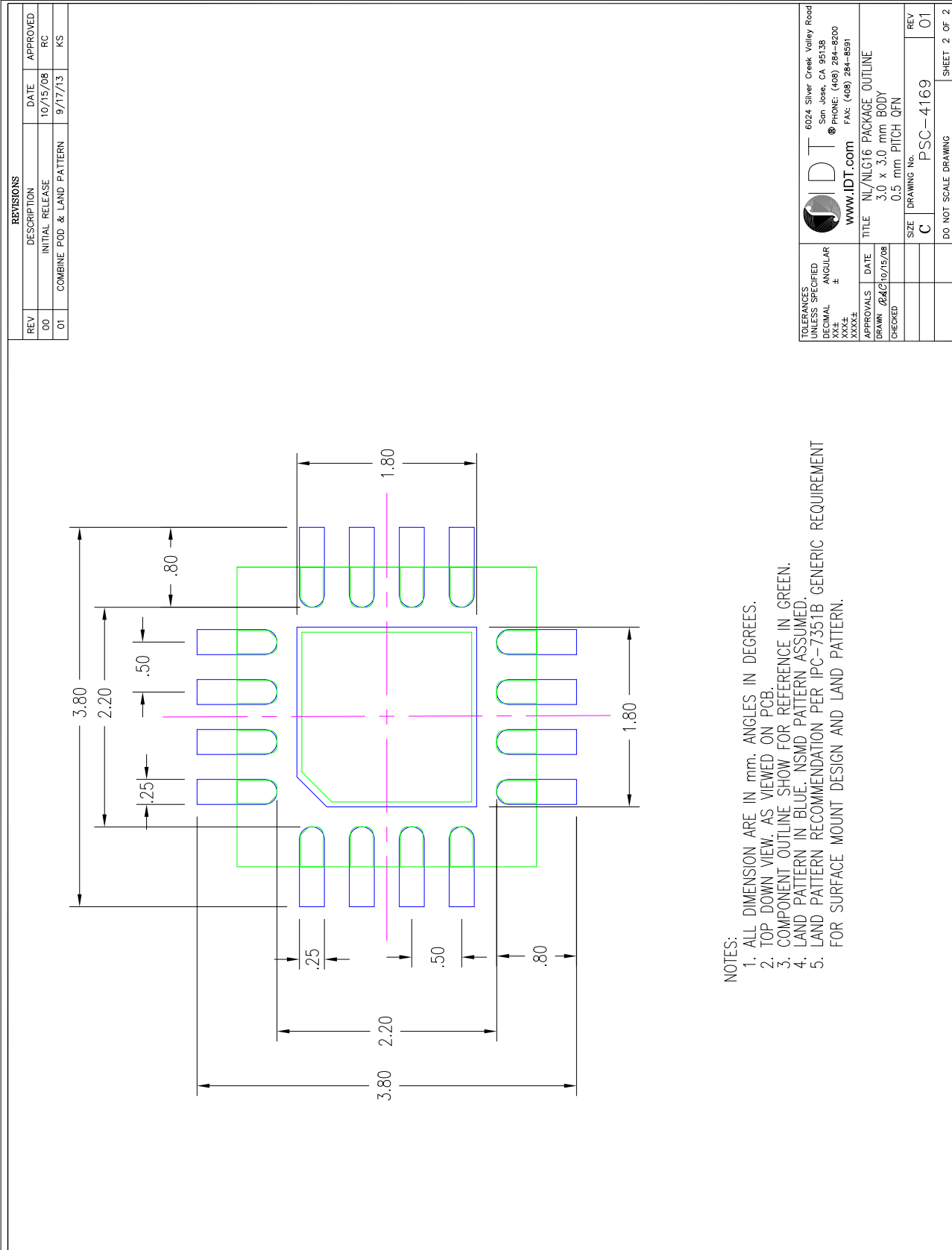

- NOTES:
1. ALL DIMENSION ARE IN mm. ANGLES IN DEGREES.
  2. TOP DOWN VIEW, AS VIEWED ON PCB.
  3. COMPONENT OUTLINE SHOW FOR REFERENCE IN GREEN.
  4. LAND PATTERN IN BLUE. NSMD PATTERN ASSUMED.
  5. LAND PATTERN RECOMMENDATION PER IPC-7351B GENERIC REQUIREMENT FOR SURFACE MOUNT DESIGN AND LAND PATTERN.

## Ordering Information

**Table 9. Ordering Information**

Part/Order Number	Marking	Package	Shipping Packaging	Temperature
840022AKI-02LF	0I2L	“Lead-Free” 16 Lead VFQFN	Tube	-40°C to 85°C
840022AKI-02LFT	0I2L	“Lead-Free” 16 Lead VFQFN	2500 Tape & Reel	-40°C to 85°C

NOTE: Parts that are ordered with an “LF” suffix to the part number are the Pb-Free configuration and are RoHS compliant.

## Revision History Sheet

Rev	Table	Page	Description of Change	Date
A		1 8	Corrected Block Diagram. Updated VFQFN EPAD Thermal Release Path section.	11/7/07
B	T4C T6C	1 3 5 6 8 11	Features Section - added 3.3V/2.5V operating supply. Added 3.3V/2.5V Power Supply DC Characteristics Table. Added 3.3V/2.5V Power Supply AC Characteristics Table. Added 3.3V/2.5V Output Load AC Test Circuit diagram. Updated Overdriving the Crystal Interface. Updated Package Drawing. Converted datasheet format.	7/28/10
B	T9	12	Ordering Information Table - corrected marking from "012L" to "0I2L".	9/27/10
C	-	11/12	Updated the package outline drawings.	5/27/2017



Corporate Headquarters  
6024 Silver Creek Valley Road  
San Jose, CA 95138 USA  
[www.IDT.com](http://www.IDT.com)

Sales  
1-800-345-7015 or 408-284-8200  
Fax: 408-284-2775  
[www.IDT.com/go/sales](http://www.IDT.com/go/sales)

Tech Support  
[www.IDT.com/go/support](http://www.IDT.com/go/support)

DISCLAIMER Integrated Device Technology, Inc. (IDT) and its affiliated companies (herein referred to as "IDT") reserve the right to modify the products and/or specifications described herein at any time, without notice, at IDT's sole discretion. Performance specifications and operating parameters of the described products are determined in an independent state and are not guaranteed to perform the same way when installed in customer products. The information contained herein is provided without representation or warranty of any kind, whether express or implied, including, but not limited to, the suitability of IDT's products for any particular purpose, an implied warranty of merchantability, or non-infringement of the intellectual property rights of others. This document is presented only as a guide and does not convey any license under intellectual property rights of IDT or any third parties.

IDT's products are not intended for use in applications involving extreme environmental conditions or in life support systems or similar devices where the failure or malfunction of an IDT product can be reasonably expected to significantly affect the health or safety of users. Anyone using an IDT product in such a manner does so at their own risk, absent an express, written agreement by IDT.

Integrated Device Technology, IDT and the IDT logo are trademarks or registered trademarks of IDT and its subsidiaries in the United States and other countries. Other trademarks used herein are the property of IDT or their respective third party owners. For datasheet type definitions and a glossary of common terms, visit [www.idt.com/go/glossary](http://www.idt.com/go/glossary). Integrated Device Technology, Inc.. All rights reserved.