

FEATURES

- 200 mbar to 35 bar (3 to 500 psi), absolute, gage or vacuum/gage pressure (custom pressure ranges on request)
- Calibrated and temperature compensated
- Rugged stainless steel isolated package
- RoHS compliant
- Quality Management System according to ISO 13485:2003 and ISO 9001:2008

MEDIA COMPATIBILITY

Wetted materials:
Stainless steel 316/316 L



SPECIFICATIONS

Maximum ratings

Supply current 2 mA

Temperature ranges
 Compensated 0 ... +50 °C
 Operating -40 ... +125 °C
 Storage -40 ... +125 °C

Insulation resistance 100 MΩ at 100 V_{DC}

Proof pressure⁵ 2 x rated pressure
 Burst pressure⁶ 4 x rated pressure

ELECTRICAL CONNECTION

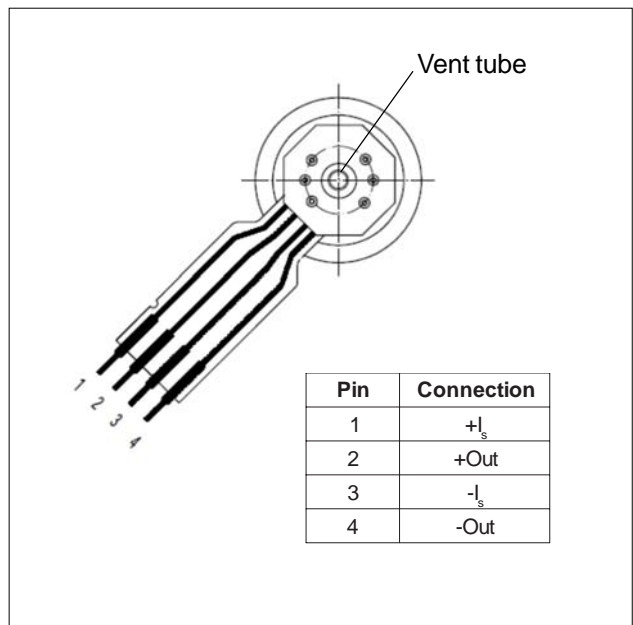

PRESSURE SENSOR CHARACTERISTICS

($I_s = 1.5 \text{ mA}_{DC}$, $T_A = 25 \text{ }^\circ\text{C}$)

Absolute devices

Part number	Operating pressure	Full-scale span ¹		
		Min.	Typ.	Max.
SSOM700A...	0...700 mbar (10.15 psi)	60 mV		90 mV
SSOB001A...	0...1 bar (14.50 psi)	60 mV		90 mV
SSOB002A...	0...2 bar (29.01 psi)	60 mV		95 mV
SSOB3x5A...	0...3.5 bar (50.76 psi)	60 mV		90 mV
SSOB007A...	0...7 bar (101.5 psi)	70 mV		85 mV
SSOB010A...	0...10 bar (145.0 psi)	70 mV		120 mV
SSOB020A...	0...20 bar (290.1 psi)	70 mV		130 mV
SSOB035A...	0...35 bar (507.6 psi)	70 mV		105 mV

Gage devices

Part number	Operating pressure	Full-scale span ¹		
		Min.	Typ.	Max.
SSOM200G...	0...200 mbar (2.901 psi)	45 mV		65 mV
SSOM350G...	0...350 mbar (5.076 psi)	60 mV		110 mV
SSOM700G...	0...700 mbar (10.15 psi)	70 mV		105 mV
SSOB001G...	0...1 bar (14.50 psi)	70 mV		90 mV
SSOB002G...	0...2 bar (29.01 psi)	70 mV		110 mV
SSOB3x5G...	0...3.5 bar (50.76 psi)	70 mV		90 mV
SSOB007G...	0...7 bar (101.5 psi)	70 mV		90 mV
SSOB010G...	0...10 bar (145.0 psi)	70 mV		130 mV
SSOB020G...	0...20 bar (290.1 psi)	70 mV		120 mV
SSOB035G...	0...35 bar (507.6 psi)	70 mV		115 mV

Vacuum/gage devices

Part number	Operating pressure	Full-scale span ¹		
		Min.	Typ.	Max.
SSOM700V...	-700...700 mbar (10.15 psi)	60 mV		105 mV
SSOB001V...	-1...1 bar (14.50 psi)	60 mV		90 mV
SSOB002V...	-1...2 bar (29.01 psi)	60 mV		110 mV
SSOB3x5V...	-1...3.5 bar (50.76 psi)	60 mV		90 mV
SSOB007V...	-1...7 bar (101.5 psi)	60 mV		90 mV
SSOB010V...	-1...10 bar (145.0 psi)	60 mV		130 mV
SSOB020V...	-1...20 bar (290.1 psi)	60 mV		120 mV
SSOB035V...	-1...35 bar (507.6 psi)	60 mV		115 mV

Note: Devices highlighted in grey are preferred stock items. For all other devices MOQ may apply.

Custom pressure ranges are available on request. Please contact First Sensor.

PERFORMANCE CHARACTERISTICS

($I_s = 1.5 \text{ mA}_{DC}$, $T_A = 25 \text{ }^\circ\text{C}$)

Characteristics			Min.	Typ.	Max.	Units
Zero pressure offset				±1	±2	mV
Non-linearity ²				±0.1	±0.2	%FSO
Repeatability				±0.01	±0.075	
Hysteresis ²				±0.01	±0.075	
Thermal effects (0 ... 50°C) ³	200 mbar devices	Offset		±0.7	±1.0	
		Span		±0.5	±0.75	
	all others	Offset		±0.3	±0.75	
		Span		±0.5	±0.75	
Long term stability ⁴				±0.1		
				±0.1		
Input impedance				4		
Output impedance				5		

Specification notes:

1. Only min. values are controlled and guaranteed, max. values are for reference only. Span is the algebraic difference between the output voltage at full scale pressure and the output at zero pressure. Full scale span is ratiometric to the supply current.
2. Non-linearity is based on **Best fit Straight Line** from the zero to the full scale pressure. Hysteresis is the maximum output difference at any point within the operating pressure range for increasing and decreasing pressure.
3. All specifications shown are relative to 25 °C.
4. Long term stability over 1 year.
5. The maximum pressure that can be applied without changing the transducer's performance or accuracy.
6. The maximum pressure that can be applied to a transducer without rupture of either the sensing element or transducer case.

PHYSICAL DIMENSIONS

SSO...1 (weld ring)

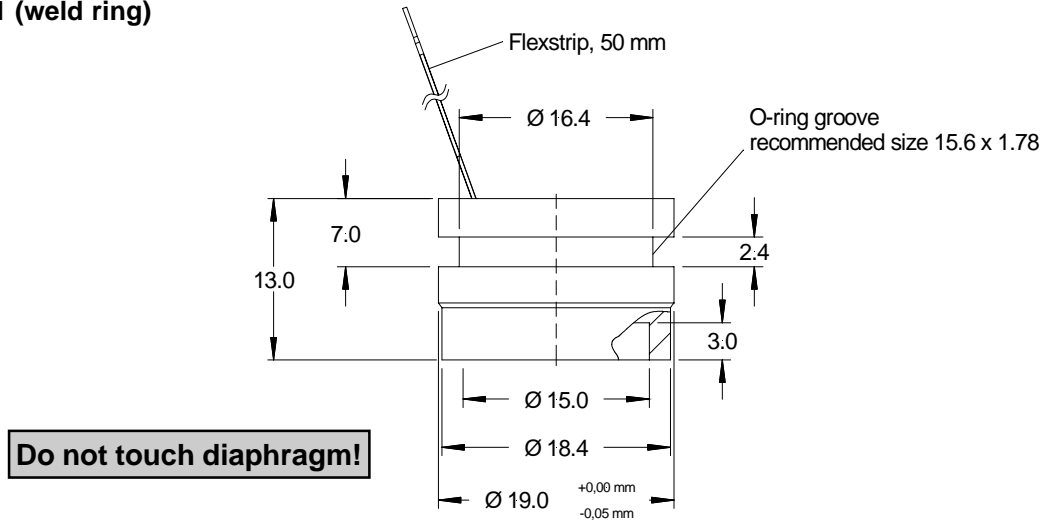

mass: approx. 17 g

dimensions in mm

A clearance fit 19H8 with 20 ° phase is recommended for mounting.

SSO...5 (1/4 " NPT)

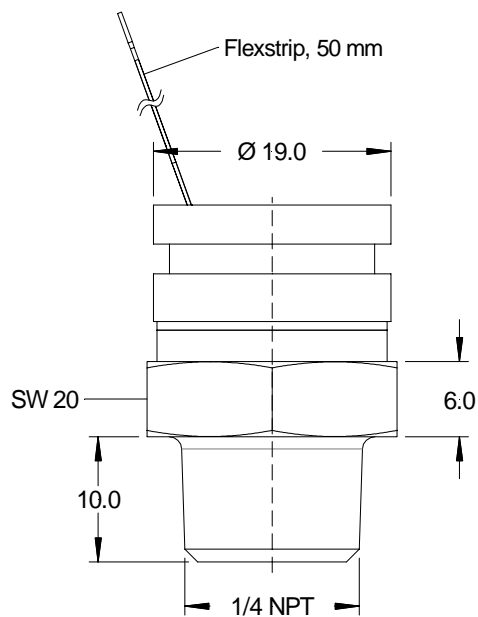

mass: approx. 50 g

dimensions in mm

PHYSICAL DIMENSIONS

SSO...8 (G 1/8 ")

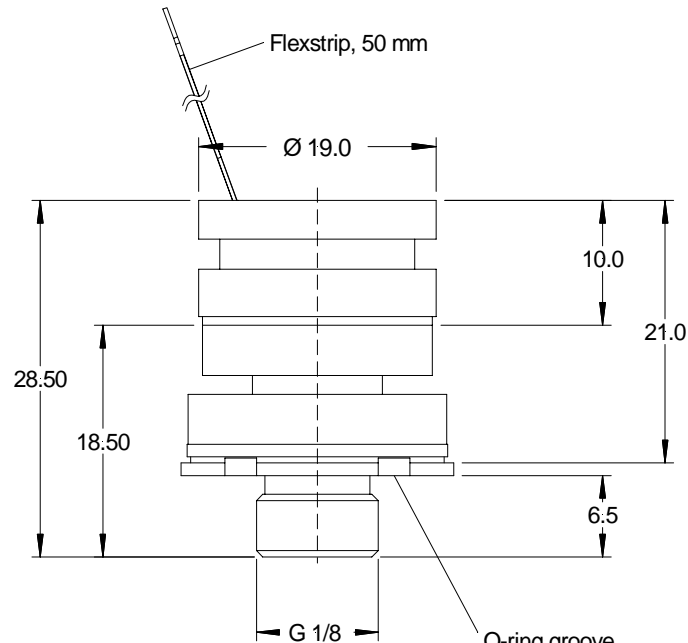

mass: approx. 35 g

O-ring groove
recommended size 11x2

dimensions in mm

A G 1/8 version with spanner flat is available on request. Please contact First Sensor.

OPTIONAL PRESSURE FITTING

SSO...N
(1/4 " NPT fitting for G 1/8 " thread)

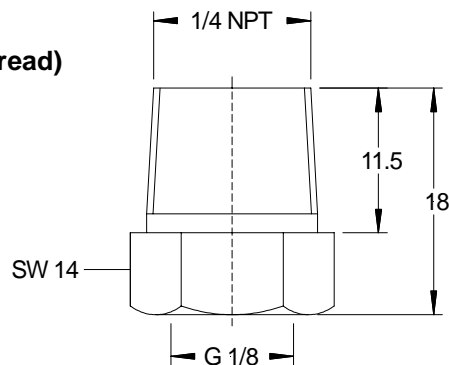

Other fittings are available on request. Please contact First Sensor.

SSO Series

Compensated stainless steel pressure sensors

ORDERING INFORMATION

Options	Series	Pressure range		Pressure mode		Housing		Electrical connection		Grade	
	SSO	M200	0...200 mbar	A*	Absolute	1	Weld ring	F	Flexstrip	H	High
		M350	0...350 mbar	G	Gage	8	G 1/8"				
		M700	0...700 mbar	V	Vacuum/gage	5	1/4" NPT				
		M700(V)	-700...700 mbar			N*	1/4" NPT				
		B001	0...1 bar				fitting				
		B001(V)	-1...1 bar								
		B002	0...2 bar								
		B002(V)	-1...2 bar								
		B3x5	0...3.5 bar								
		B3x5(V)	-1...3.5 bar								
		B007	0...7 bar								
		B007(V)	-1...7 bar								
		B010	0...10 bar								
		B010(V)	-1...10 bar								
		B020	0...20 bar								
		B020(V)	-1...20 bar								
		B035	0...35 bar								
	B035(V)	-1...35 bar									
				* from 700 mbar upwards only		* 1/4" NPT fitting on G 1/8" thread					
Example: SSO B001 G 8 F H											

Note: Devices highlighted in grey are preferred stock items. For all other devices MOQ may apply.

Custom pressure ranges and other pressure fittings are available on request. MOQ may apply. Please contact First Sensor.

First Sensor reserves the right to make changes to any products herein. First Sensor does not assume any liability arising out of the application or use of any product or circuit described herein, neither does it convey any license under its patent rights nor the rights of others.

