



TS9010

150mA CMOS Low Dropout Voltage Regulator with Enable

SOT-25



Pin assignment

1. Input
2. Ground
3. Enable
4. Bypass
5. Output

Low Power Consumption
Low Drop Out Voltage 0.4V
Enable Shutdown

General Description

The TS9010 series is combine high accuracy with very low power consumption, providing high output current even when the application requires very low dropout voltage. The Chip Enable (CE) includes a CMOS or TTL compatible input allows the output to be turned off to prolong battery life. The TS9010 series is included a precision voltage reference, error correction circuit, a current limited output driver, over temperature shutdown, and a reference bypass pin to improve its already excellent low-noise performance.

This series are offered in 5-pin SOT-25 package.

Features

- ◇ Dropout voltage typically 0.4V @Io=150mA (Vo=5V)
- ◇ Output current up to 150mA (Vout=3V)
- ◇ Low power consumption
- ◇ Output voltage +/-2%
- ◇ Internal current limit
- ◇ Thermal shutdown protection

Applications

- ◇ Palmtops
- ◇ Video recorders
- ◇ Battery powered equipment
- ◇ PC peripherals
- ◇ High-efficiency linear power supplies
- ◇ Digital signal camera

Block Diagram

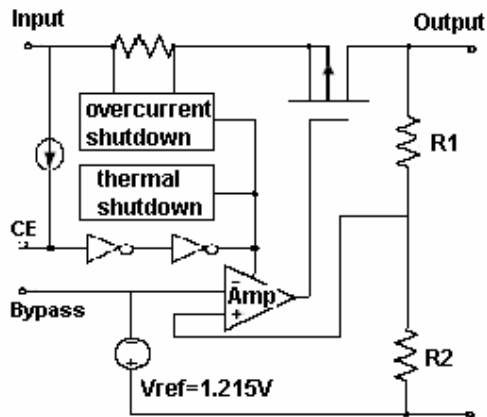

Ordering Information

Part No.	Operating Temp. (Ambient)	Package
TS9010xCX5	-40 ~ +85°C	SOT-25

Note: Where **x** denotes voltage option, available are

- D**=1.8V,
- K**=2.5V,
- P**=3.0V,
- S**=3.3V,
- 5**=5.0V.

Contact factory for additional voltage options.

Typical Application Circuit

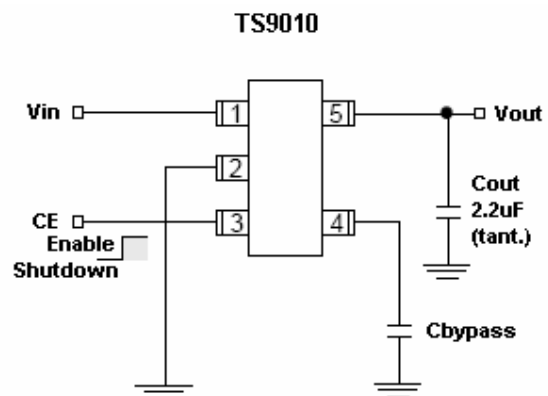

CE (pin 3) may be connected directly to Vin (pin 1)

Low noise operation: Cbypass=470pF, Cout>2.2uF

Basic operation: Cbypass=not used, Cout>1uF



Absolute Maximum Rating (Note 1)						
Input Supply Voltage	V _{in}	+12			V	
Enable Input Voltage	V _{ce}	0 ~ V _{in} +0.3			V	
Output Current	I _o	200			mA	
Power Dissipation (Note 3)	P _D	380			mW	
Thermal Resistance	θ _{ja}	220			°C/W	
Operating Junction Temperature Range	T _j	-40 ~ +125			°C	
Storage Temperature Range	T _{STG}	-65 ~ +150			°C	
Lead Soldering Temperature (260 °C)		5			S	
Recommend Operating Rating						
Input Supply Voltage	V _{in}	+16			V	
Enable Input Voltage	V _{ce}	Gnd-0.3 ~ V _{in} +0.3			V	
Electrical Characteristics						
Ta = 25 °C, I _o =1mA, C _{out} =2.2uF, V _{ce} ≥2V, unless otherwise specified.						
Parameter	Conditions		Min	Typ	Max	Unit
Output Voltage	V _{in} =V _o + 1V		0.98 V _o		1.02 V _o	V
Output Voltage Temperature Coefficient (Note 4)			--	100	--	ppm/°C
Line Regulation	V _o +1V ≤ V _{in} ≤ 10V		--	10	20	mV
Load Regulation (Note 5)	V _{in} =V _o +1V, 1mA ≤ I _L ≤ 150mA	TS9011S	--	30	80	mV
		TS9011S				
	V _{in} =V _o +1V, 1mA ≤ I _L ≤ 80mA	TS9011K	--	40	90	
		TS9011D				
Dropout Voltage (Note 6)	I _o =150mA	TS9011S	--	400	--	mV
	I _o =150mA	TS9011S	--	400	--	
	I _o =100mA	TS9011K	--	600	--	
	I _o =100mA	TS9011D	--	800	1000	
Quiescent Current	V _{in} ≤ 0.4V (shutdown)		--	0.01	1	uA
Ground Pin Current (Note 7)	V _{ce} ≥ 2V	I _o =0.1mA	--	80	125	uA
		I _o =50mA	--	350	600	
		I _o =100mA	--	600	1000	
		I _o =150mA	--	1300	1900	
Output Current Limit	V _{out} =0V		--	300	--	mA
Power Supply Rejection Ratio	At f=100Hz, I _o =0.1mA,		--	70	--	dB
Thermal Regulation (Note 8)			--	0.05	--	%/W
Output Noise	I _o =50mA, C _{out} =2.2uF, 470pF from bypass to Ground		--	260	--	nV/√Hz



Electrical Characteristics					
Enable Input					
Parameter	Conditions	Min	Typ	Max	Unit
Enable Input Logic-Low Voltage	Regulation shutdown	--	--	0.4	V
Enable Input Logic-High Voltage	Regulation enable	2.0	--	--	V
Enable Input Current	$V_{IL} \leq 0.4V$	--	0.01	1	uA
	$V_{IL} \geq 2.0V$	2	5	20	

Note 1: Exceeding the absolute maximum rating may damage the device.

Note 2: The device is not guaranteed to function outside its operating rating.

Note 3: The maximum allowable power dissipation at any T_a is $P_d(\max) = [T_j(\max) - T_a] * \theta_{ja}$. Exceeding the maximum allowable power dissipation will result in excessive die temperature, and the regulator will go into thermal shutdown.

Note 4: Output voltage temperature coefficient is defined as the worst case voltage change divided by the total temperature range.

Note 5: Regulation is measured at constant junction temperature using low duty cycle pulse testing. Parts are tested for load regulation in the load range from 1mA to 150mA ($V_{out} > 2.5V$) and 1mA to 80mA ($V_{out} < 2.5V$). Changes in output voltage due to heating effects are covered by the thermal regulation specification.

Note 6: Dropout voltage is defined as the input to output differential at which the output voltage drops 2% below its nominal value measured at 1V differential.

Note 7: Ground pin current is the regulator quiescent current plus pass transistor base current. The total current drawn from the supply is the sum of the load current plus the ground pin current.

Note 8: Thermal regulation is defined as the change in output voltage at a time "t" after a change in power dissipation is applied, excluding load or line regulation effects. Specifications are for a 150mA load pulse at $V_{in} = 12V$ for $t = 10mS$.

Application Examples

Standard Circuit

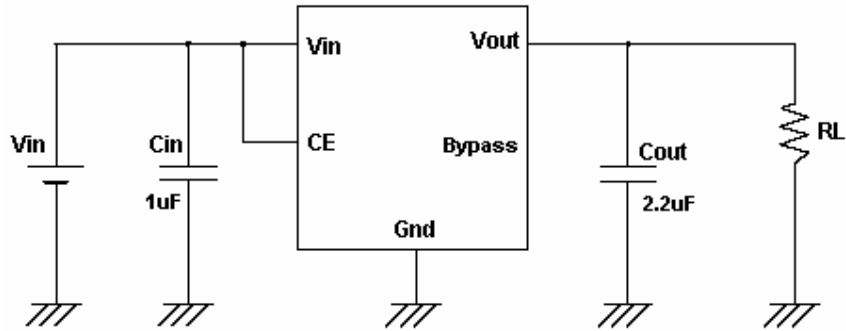

Typical Application Circuit 1

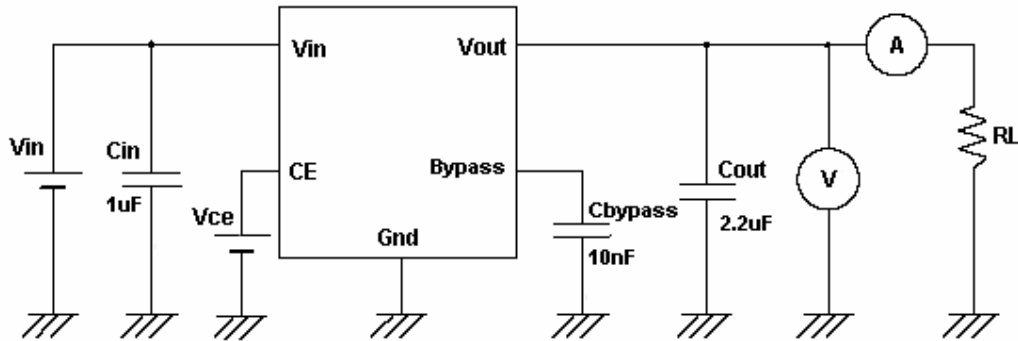

Typical Application Circuit 2

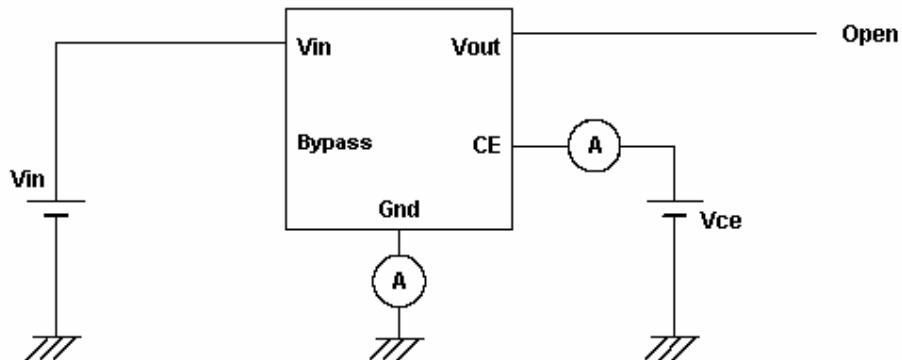

SOT-25 Mechanical Drawing

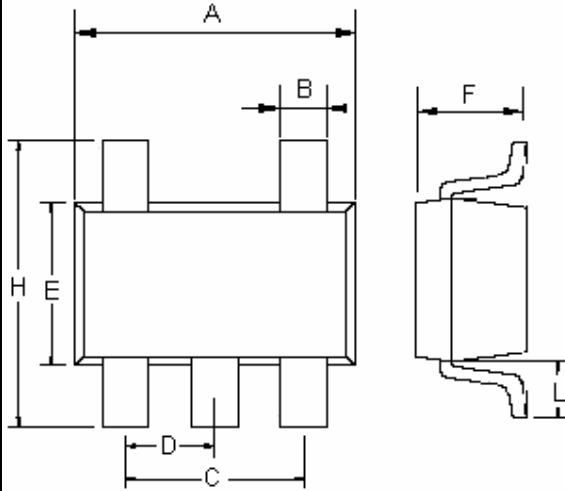

SOT-23 DIMENSION				
DIM	MILLIMETERS		INCHES	
	MIN	MAX	MIN	MAX
A	2.70	3.00	0.106	0.118
B	0.25	0.50	0.010	0.020
C	1.90(typ)		0.075(typ)	
D	0.95(typ)		0.037(typ)	
E	1.50	1.70	0.059	0.067
F	1.05	1.35	0.041	0.053
H	2.60	3.00	0.102	0.118
L	0.60(typ)		0.024(typ)	