

RXO7050P



SMD Clock Oscillator

High Performance XO in 7 x 5 mm Surface Mount package

Product description

The RXO7050P XO combines very low RMS phase jitter and tight frequency stability in an industry standard 7 x 5 mm SMD package. Available in hundreds of industry standard frequencies from 8 to 800 MHz for fast delivery and reduced inventory levels.

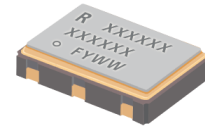

Applications

- Basestation
- Communications
- Consumer Products
- DSL/ADSL
- Ethernet (10G/40G/100G)
- WiFi
- WiMAX/WLAN

Features

- 0.5 ps integrated RMS phase jitter (12 kHz to 20 MHz)
- Fast sample turnaround available
- LVCMOS, LVPECL, or LVDS Output options
- Wide frequency range
- Low power differential outputs

Specifications

1.0 SPECIFICATION REFERENCES

Line	Parameter	Description
1.1	Model Description	RXO7050P XO
1.2	Reference Number	
1.3	Rakon Part Number	

2.0 FREQUENCY CHARACTERISTICS

Line	Parameter	Test Condition	Value	Unit
2.1	Frequency		8 to 1500	MHz
2.2	Operating Temperature Range		-40 to 85	°C
2.3	Frequency Stability	Including Temperature range, Supply variation, Load variation and 10 years aging at 25°C	±30 to 50	ppm
2.4	Temperature Stability	Temperature range only	±10 to 20	ppm

3.0 POWER SUPPLY

Line	Parameter	Test Condition	Value	Unit
3.1	Supply Voltage (VDD)	With a tolerance of ±10%	3.3	V
3.2	Supply Voltage (VDD)	With a tolerance of ±5%	2.5	V
3.3	Supply Current	For LVCMOS	30 max	mA
3.4	Supply Current	For LVPECL	65 max	mA
3.5	Supply Current	For LVDS	40 max	mA

4.0 OUTPUT CHARACTERISTICS - LVCMOS (UP TO 200 MHz)

Line	Parameter	Test Condition	Value	Unit
4.1	Output Voltage (Vol)	15pF load	10 max	%VDD
4.2	Output Voltage (Voh)	15pF load	90 min	%VDD
4.3	Duty Cycle	@ 50% VDD	48 to 52	%
4.4	Rise Time / Fall Time	90%/10%	3 max	ns
4.5	RMS Phase Jitter	Integrated 12kHz to 20MHz	0.5	ps

5.0 OUTPUT CHARACTERISTICS - LVPECL ONLY

Line	Parameter	Test Condition	Value	Unit
5.1	Output Voltage (Vol)	50Ω nominal load. (VDD - 1.6V) max.		
5.2	Output Voltage (Voh)	50Ω nominal load. (VDD - 1.03V) min.		
5.3	Duty Cycle	@ VDD-1.3V (45 to 55% over 600MHz)	48 to 52	%
5.4	Rise Time / Fall Time	80%/20%	0.6 max	ns
5.5	RMS Phase Jitter	Integrated 12kHz to 20MHz	0.5	ps

6.0 OUTPUT CHARACTERISTICS - LVDS ONLY

Line	Parameter	Test Condition	Value	Unit
6.1	Differential Output: Voltage Swing (Vod)		350	mV
6.2	Duty Cycle	Measured at 1.25V (45 to 55% over 150MHz)	48 to 52	%
6.3	Rise Time / Fall Time	RL = 100 Ω / CL = 10 pF	0.6 max	ns
6.4	RMS Phase Jitter	Integrated 12kHz to 20MHz	0.5	ps

7.0 PIN CONNECTIONS

Line	Parameter	Description
7.1	Pin 1	E/D* or NC
7.2	Pin 2	E/D* or NC
7.3	Pin 3	GND
7.4	Pin 4	OUTPUT
7.5	Pin 5	COMPLIMENTARY OUTPUT (LVPECL/LVDS only), or E/D*, or NC
7.6	Pin 6	VDD
7.7	* Output Enabled	>70% of VDD on E/D pin, or E/D pin left open (connected to internal pull-up resistor)
7.8	* Output Disabled	<30% of VDD on E/D pin, or E/D pin to GND

8.0 PACKAGE DETAILS

Line	Parameter	Description
8.1	Package	B
8.2	Top line	[R #####] Part identifier
8.3	Middle line	[#####] Part information
8.4	Bottom line	[o FYWW] Pin 1, Manufacturing code, Year code* and Week code**
8.5	* Year code	A = 2010, B = 2011, C = 2012, D = 2013, ... Z = 2035
8.6	** Week Code	WW = 01 = Week of first Monday of the year

9.0 ENVIRONMENTAL SPECIFICATION

Line	Parameter	Description
9.1	Mechanical Shock	MIL-STD-883, Method 2002
9.2	Storage Temperature Range	-55 to 125 °C
9.3	Humidity	After 48 hours at 85 °C±2 °C 85 % relative humidity non-condensing
9.4	Thermal Shock	MIL-STD-883, Method 1011
9.5	Vibration	MIL-STD-883, Method 2007
9.6	Gross and Fine Leak	MIL-STD-883, Method 1014
9.7	RoHS Compliant	Yes

10.0 MANUFACTURING INFORMATION

Line	Parameter	Description
10.1	Packaging Description	Tape and Reel. Standard packing quantity is 2000 per reel
10.2	Reflow	Solder reflow process as per attached profile

Drawing Name: XO/VCXO 7050 Model Drawing

PACKAGE A

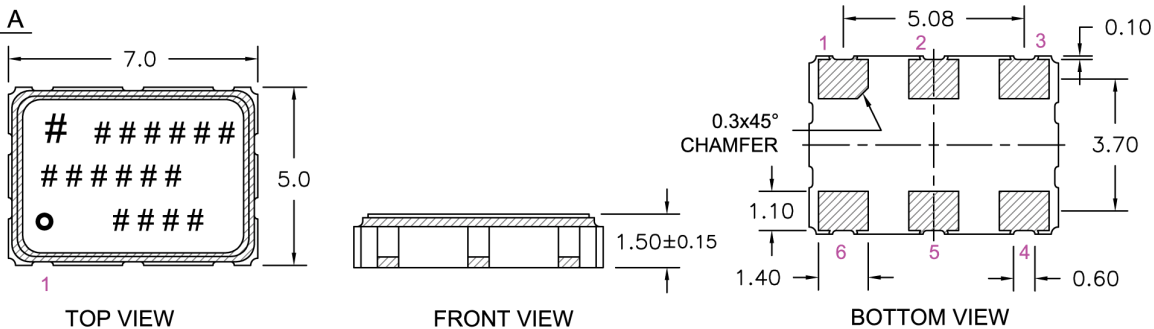

PACKAGE B

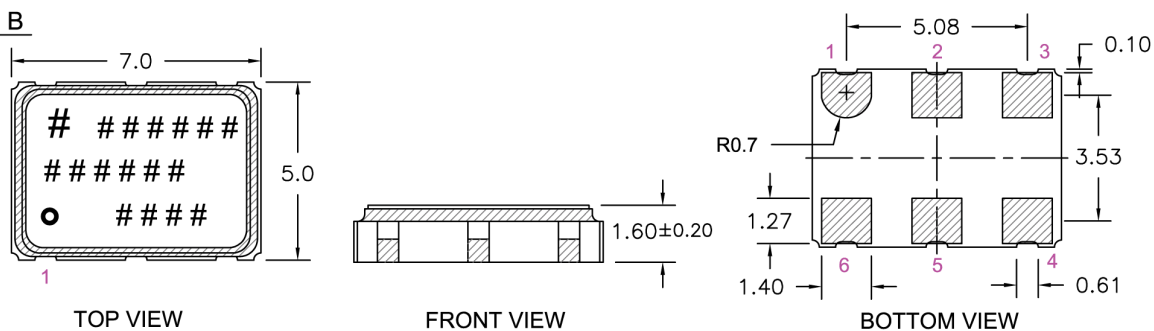

PACKAGE C

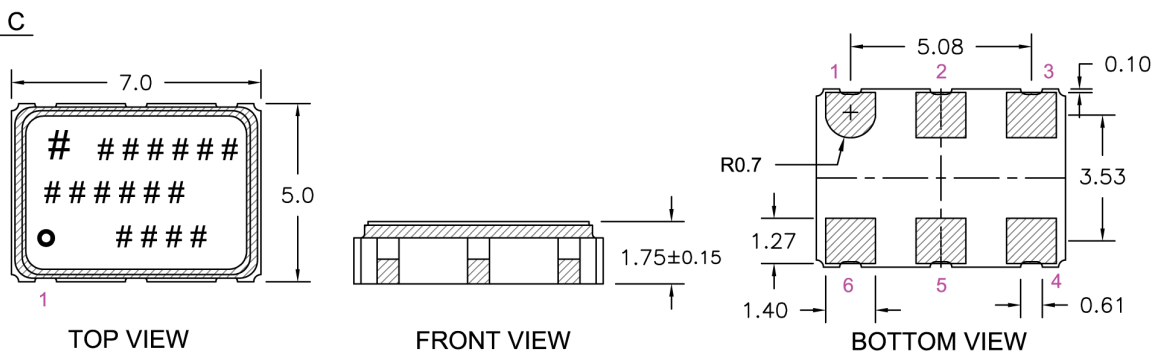

RECOMMENDED PAD LAYOUT

- TOP VIEW

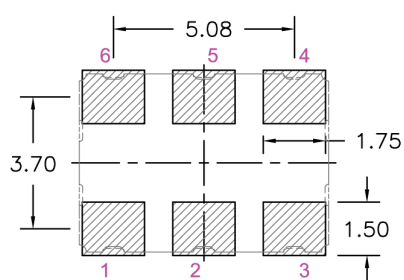

NOTE :

1. PIN CONNECTIONS ARE DETAILED IN THE SPECIFICATION.
2. MARKING INFORMATION IS DETAILED IN THE SPECIFICATION.

TITLE: XO/VCXO 7050 SERIES MODEL

FILENAME: CAT207

TOLERANCES:

RELATED DRAWINGS:

REVISION: J

XX =

DATE: 03-Apr-12

X.X = ±0.15

SCALE: 5 : 1

X.XX = ±0.10

Millimetres

X.XXX =

X° =

Hole =



© 2009 Rakon Limited

Drawing Name: XO/VCXO 6 Pin Series Test Circuit

LVC MOS TEST CIRCUIT:

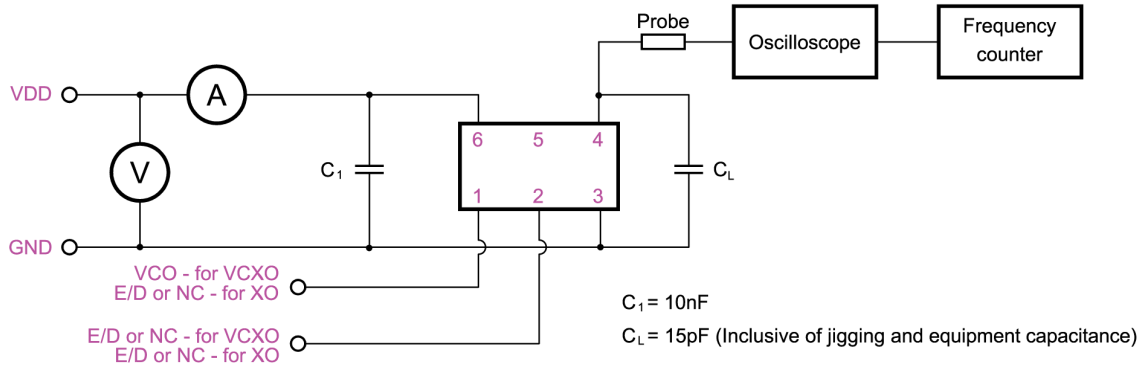

LVPECL TEST CIRCUIT:

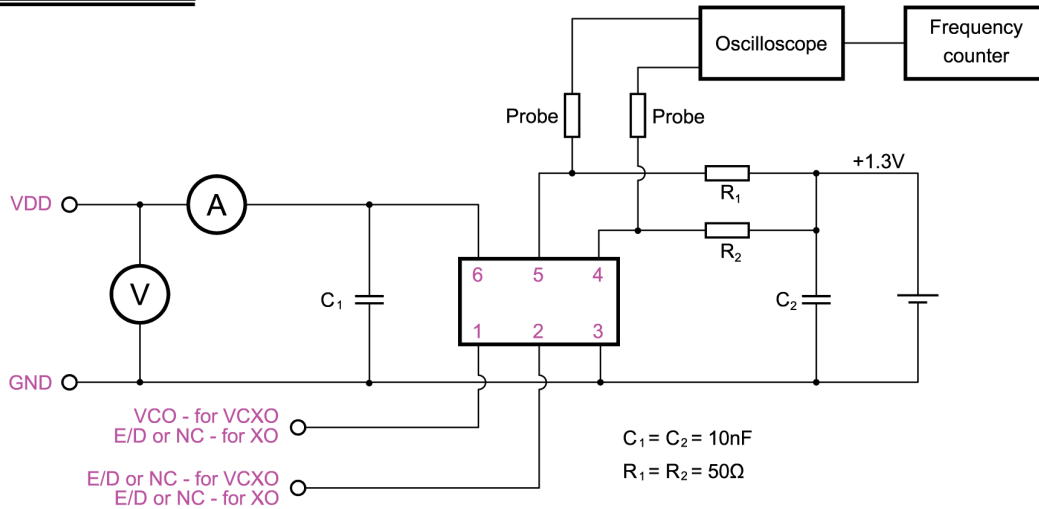

LVDS TEST CIRCUIT:

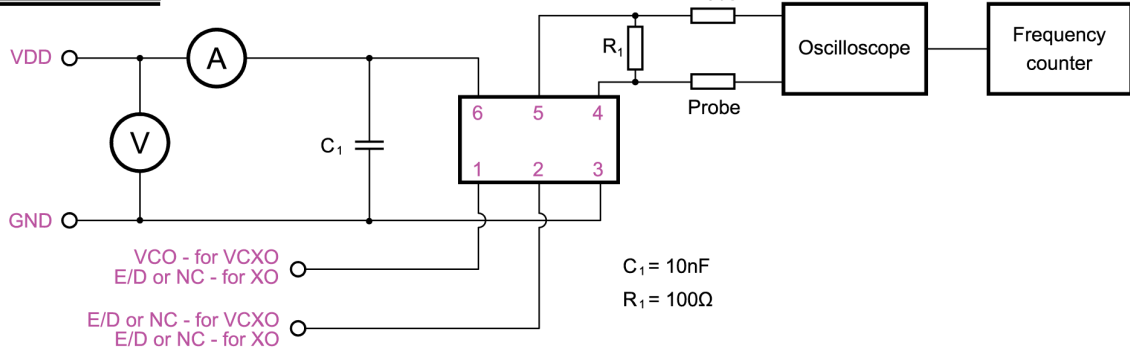

TITLE: XO/VCXO 6 PIN SERIES TEST CIRCUIT

FILENAME: CAT088

RELATED DRAWINGS:

REVISION: F
DATE: 03-May-12
SCALE: 1 : 1
Millimetres



© 2009 Rakon Limited

Drawing Name: XO/VCXO 7050 Series Tape & Reel

TAPE DETAIL (SCALE 2 : 1)

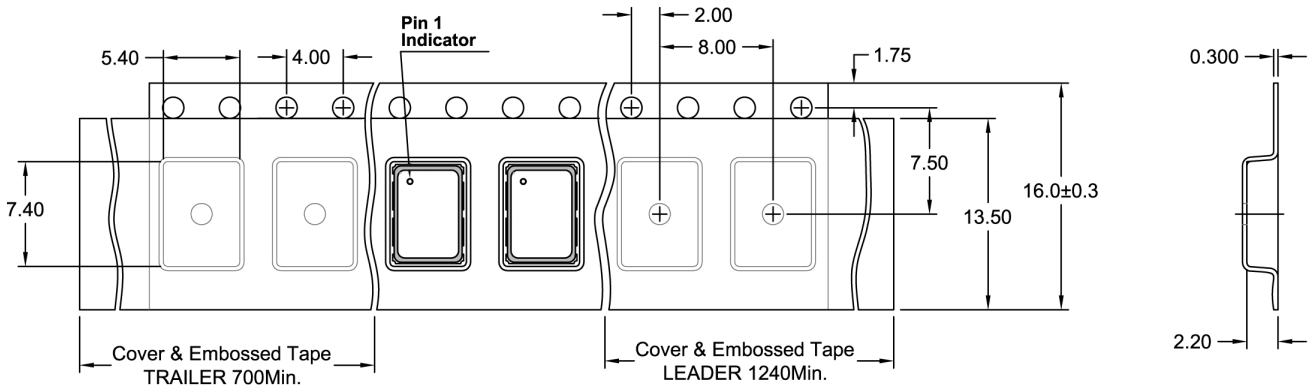

REEL DETAIL (SCALE 1 : 2.5)

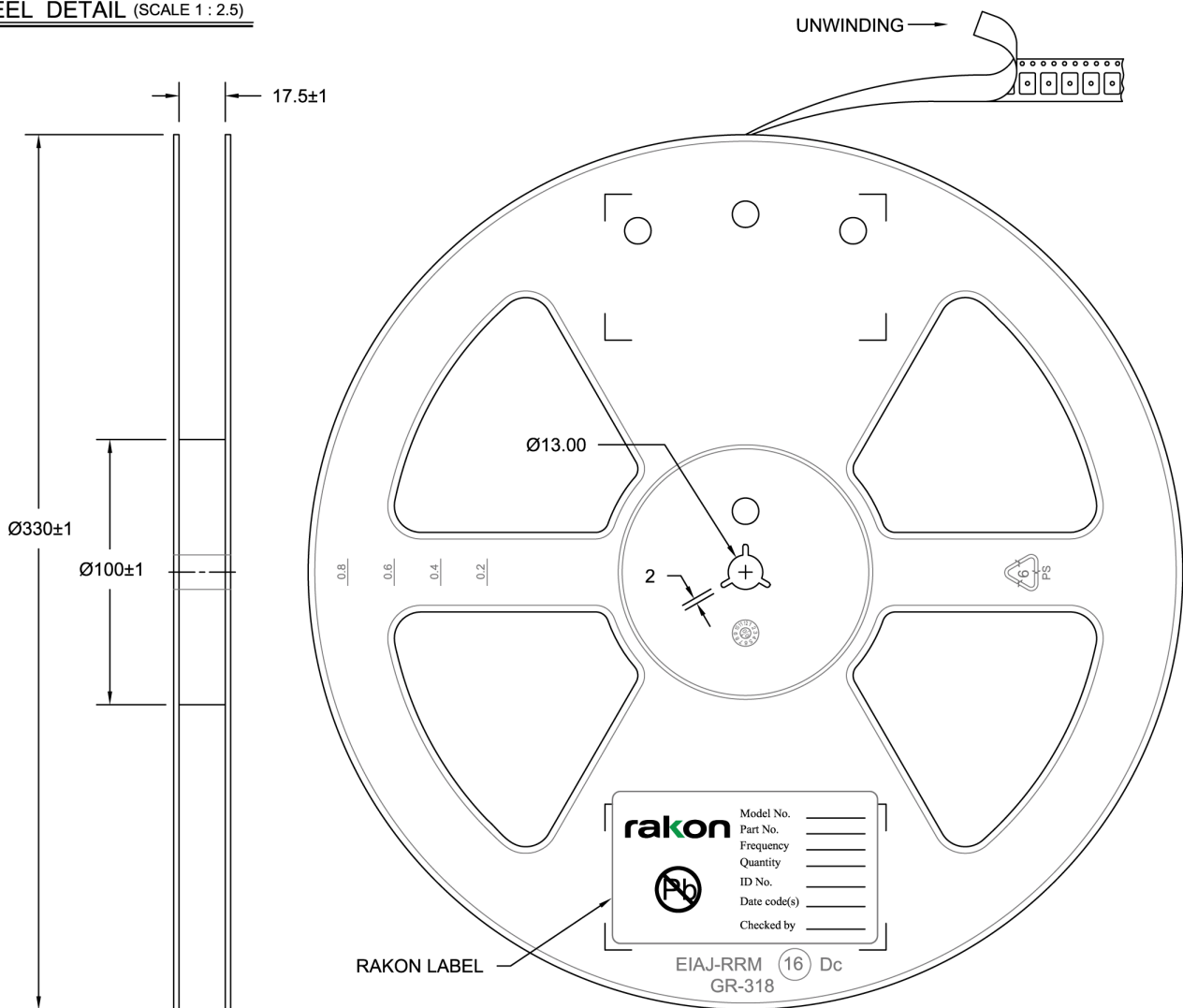

TITLE: XO/VCXO 7050 SERIES TAPE & REEL

RELATED DRAWINGS:

FILENAME: CAT032

REVISION: D

DATE: 05-Sep-11

SCALE: 2 : 1

Millimetres

TOLERANCES:

XX = ±0.5

X.X = ±0.2

X.XX = ±0.10

X.XXX = ±0.05

X° =

Hole =

rakon

© 2009 Rakon Limited

Drawing Name: Pb-Free Reflow

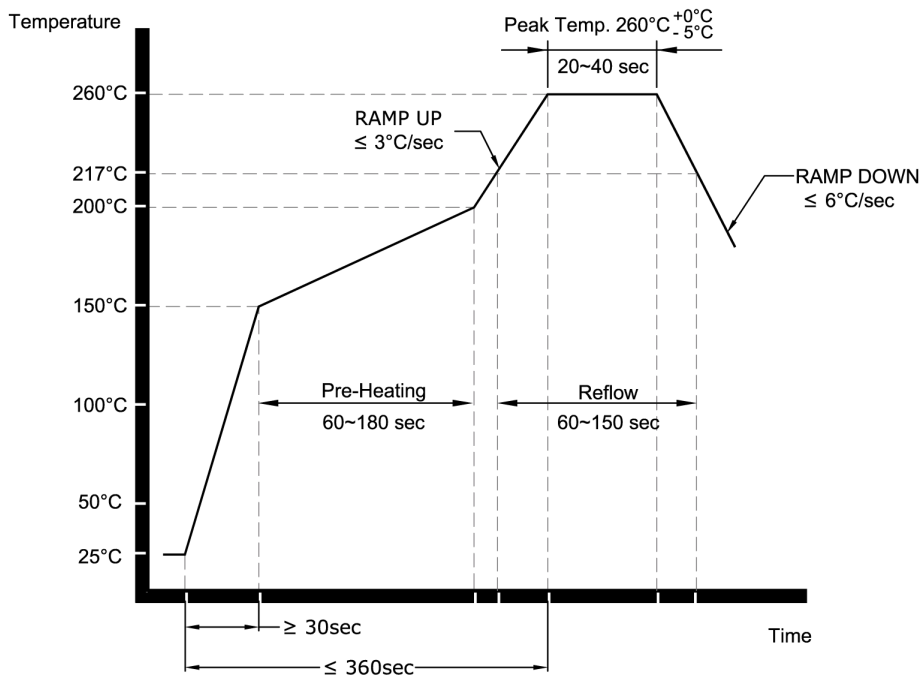

NOTE:

The product has been tested to withstand the Reflow Profile shown. The Reflow Profile used to solder Rakon products is determined by the solder paste Manufacturer's specification. It is recommended that the Reflow Profile used does not exceed the one shown above.

TITLE: Pb-FREE REFLOW

FILENAME: CAT541

RELATED DRAWINGS:

REVISION: B
 DATE: 05-Sep-11
 SCALE: NTS
 Millimetres



© 2009 Rakon Limited