

# CM1231-02SO

## 2, 4 and 8-Channel Low-Capacitance ESD Protection Array

### Product Description

The CM1231-02SO is a member of the XtremeESD™ product family and is specifically designed for next generation deep submicron ASIC protection. These devices are ideal for protecting systems with high data and clock rates and for circuits requiring low capacitive loading such as USB 2.0.

The CM1231-02SO incorporates the PicoGuard XP™ dual stage ESD architecture which offers dramatically higher system level ESD protection compared with traditional single clamp designs. In addition, the CM1231-02SO provides a controlled filter roll-off for even greater spurious EMI suppression and signal integrity.

The CM1231-02SO protects against ESD pulses up to ±12 kV contact on the “OUT” pins per the IEC 61000-4-2 standard.

The device also features easily routed “pass-through” differential pinouts in a 6-lead SOT23 package.

### Features

- Two Channels of ESD Protection
- Exceeds ESD Protection to IEC61000-4-2 Level 4:
  - ±12 kV Contact Discharge (OUT Pins)
- Two-Stage Matched Clamp Architecture
- Matching-of-Series Resistor (R) of ±10 mΩ Typical
- Flow-Through Routing for High-Speed Signal Integrity
- Differential Channel Input Capacitance Matching of 0.02 pF Typical
- Improved Powered ASIC Latchup Protection
- Dramatic Improvement in ESD Protection vs. Best in Class Single-Stage Diode Arrays
  - 40% Reduction in Peak Clamping Voltage
  - 40% Reduction in Peak Residual Current
- Withstands over 1000 ESD Strikes\*
- Available in a SOT23-6 Package
- These Devices are Pb-Free and are RoHS Compliant

### Applications

- USB Devices Data Port Protection
- General High-Speed Data Line ESD Protection



ON Semiconductor®

<http://onsemi.com>

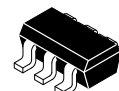

SOT23-6  
SO SUFFIX  
CASE 527AJ

### MARKING DIAGRAM

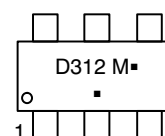

D312 = Specific Device Code  
M = Date Code  
▪ = Pb-Free Package

(Note: Microdot may be in either location)

### ORDERING INFORMATION

Device	Package	Shipping†
CM1231-02SO	SOT23-6 (Pb-Free)	3000/Tape & Reel

†For information on tape and reel specifications, including part orientation and tape sizes, please refer to our Tape and Reel Packaging Specification Brochure, BRD8011/D.

\*Standard test condition is IEC61000-4-2 level 4 test circuit with each (A<sub>OUT</sub>/B<sub>OUT</sub>) pin subjected to ±12 kV contact discharge for 1000 pulses. Discharges are timed at 1 second intervals and all 1000 strikes are completed in one continuous test run.

# CM1231-02SO

## ELECTRICAL SCHEMATIC

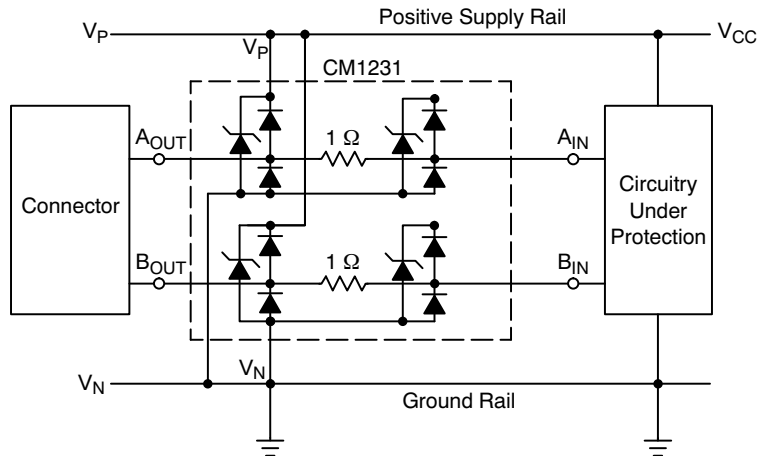

**Table 1. PIN DESCRIPTIONS**

Pin	Name	Description
1	A <sub>OUT</sub>	Bidirectional clamp to Connector (Outside the system)
2	V <sub>N</sub>	Ground return to Shield
3	A <sub>IN</sub>	Bidirectional clamp to ASIC (Inside the system)
4	B <sub>IN</sub>	Bidirectional clamp to ASIC (Inside the system)
5	V <sub>P</sub>	Bias voltage (optional)
6	B <sub>OUT</sub>	Bidirectional clamp to Connector (Outside the system)

## PACKAGE / PINOUT DIAGRAMS

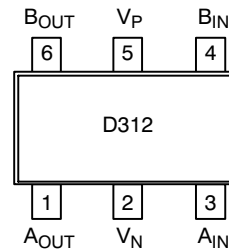

## SPECIFICATIONS

**Table 2. ABSOLUTE MAXIMUM RATINGS**

Parameter	Rating	Units
Operating Supply Voltage (V <sub>P</sub> )	6.0	V
Diode Forward DC Current (A <sub>OUT</sub> /B <sub>OUT</sub> Side)	8.0	mA
Continuous Current through Signal Pins (IN to OUT) 1000 hours	125	mA
Operating Temperature Range	-40 to +85	°C
Storage Temperature Range	-65 to +150	°C
DC Voltage at any channel input	(V <sub>N</sub> - 0.5) to (V <sub>P</sub> + 0.5)	V
Package Power Rating (SOT23-6)	225	mW

Stresses exceeding Maximum Ratings may damage the device. Maximum Ratings are stress ratings only. Functional operation above the Recommended Operating Conditions is not implied. Extended exposure to stresses above the Recommended Operating Conditions may affect device reliability.

# CM1231-02SO

**Table 3. ELECTRICAL OPERATING CHARACTERISTICS** (Note 1)

Symbol	Parameter	Conditions	Min	Typ	Max	Units
V <sub>P</sub>	Operating Supply Voltage			5	5.5	V
I <sub>CC5</sub>	Operating Supply Current	V <sub>P</sub> = 5 V			1	μA
V <sub>F</sub>	Diode Forward Voltage Top Diode Bottom Diode	I <sub>F</sub> = 8 mA, T <sub>A</sub> = 25°C	0.60 0.60	0.80 0.80	0.95 0.95	V
V <sub>ESD</sub>	ESD Protection, Contact Discharge per IEC 61000-4-2 Standard OUT-to-V <sub>N</sub> Contact IN-to-V <sub>N</sub> Contact	T <sub>A</sub> = 25°C	±12 ±4			kV
I <sub>RES</sub>	Residual ESD Peak Current on RDUP (Resistance of Device Under Protection)	IEC 61000-4-2 8 kV RDUP = 5 Ω, T <sub>A</sub> = 25°C		2.3		A
V <sub>CL</sub>	Channel Clamp Voltage Positive Transients Negative Transients	I <sub>PP</sub> = 1 A, T <sub>A</sub> = 25°C, t <sub>P</sub> = 8/20 μs, Zap at OUT, Measure at IN		+9 -1.4		V
R <sub>DYN</sub>	Dynamic Resistance Positive Transients Negative Transients	I <sub>PP</sub> = 1 A, T <sub>A</sub> = 25°C, t <sub>P</sub> = 8/20 μs, Zap at OUT, Measure at IN		0.4 0.3		Ω
C <sub>OUT</sub>	OUT Capacitance	f = 1 MHz, V <sub>P</sub> = 5.0 V, V <sub>IN</sub> = 2.5 V, V <sub>OSC</sub> = 30 mV (Note 2)		1.5		pF
ΔC <sub>OUT</sub>	Channel to Channel Capacitance Match	f = 1 MHz, V <sub>P</sub> = 5.0 V, V <sub>IN</sub> = 2.5 V, V <sub>OSC</sub> = 30 mV		0.02		pF
R <sub>S</sub>	Series Resistance			1		Ω
ΔR <sub>S</sub>	Channel to Channel Resistance Match			±10	±30	mΩ

1. All parameters specified at T<sub>A</sub> = -40°C to +85°C unless otherwise noted.
2. Capacitance measured from OUT to V<sub>N</sub> with IN floating.

**SINGLE AND DUAL CLAMP ESD PROTECTION**

The following sections describe the standard single clamp ESD protection device and the dual clamp ESD protection architecture of the CM1231-02SO.

**Single Clamp ESD Protection**

Conceptually, an ESD protection device performs the following actions upon a strike of ESD discharge into the protected ASIC (see Figure 1).

1. When an ESD potential is applied to the system under test (contact or air-discharge), Kirchoff's Current Law (KCL) dictates that the Electrical Overstress (EOS) currents will immediately divide throughout the circuit, based on the dynamic impedance of each path
2. Ideally, the classic shunt ESD clamp will switch within 1 ns to a low-impedance path and return the majority of the EOS current to the chassis shield/reference ground. In actuality, if the ESD component's response time ( $t_{CLAMP}$ ) is slower than the ASIC it is protecting, or if the Dynamic Resistance ( $R_{DYN}$ ) is not significantly lower than the ASIC's I/O cell circuitry, then the ASIC will have to absorb a large amount of the EOS energy, and may be more likely to fail.
3. Subsequent to the ESD/EOS event, both devices must immediately return to their original specifications, ready for an additional strike. Any deterioration in parasitics or clamping capability should be considered a failure, as it can affect signal integrity or subsequent protection capability (this is known as "multi-strike" capability.)

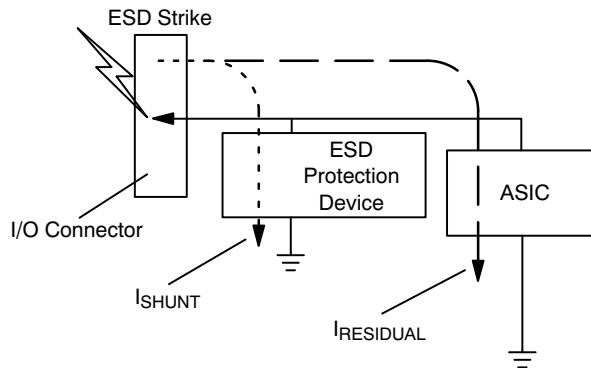

**Figure 1. Single Clamp ESD Protection Block Diagram**

**Dual Clamp ESD Protection**

In the CM1231-02SO dual clamp *PicoGuard XP*™ architecture, the first stage begins clamping immediately, as it does in the single clamp case. The dramatically reduced  $I_{RES}$  current from stage one passes through the 1 Ω series element and then gradually feeds into the stage two ESD device (see Figure 2). The series inductive and resistive elements further limit the current into the second stage, and greatly attenuate the resultant peak incident pulse presented at the ASIC side of the device.

This disconnection between the outside node and the inside ASIC node allows the stage one clamps to turn on and remain in the shunt mode before the ASIC begins to shunt the reduced residual pulse. This gives the advantage to the ESD component in the current division equation, and dramatically reduces the residual energy that the ASIC must dissipate.

## CM1231-02SO

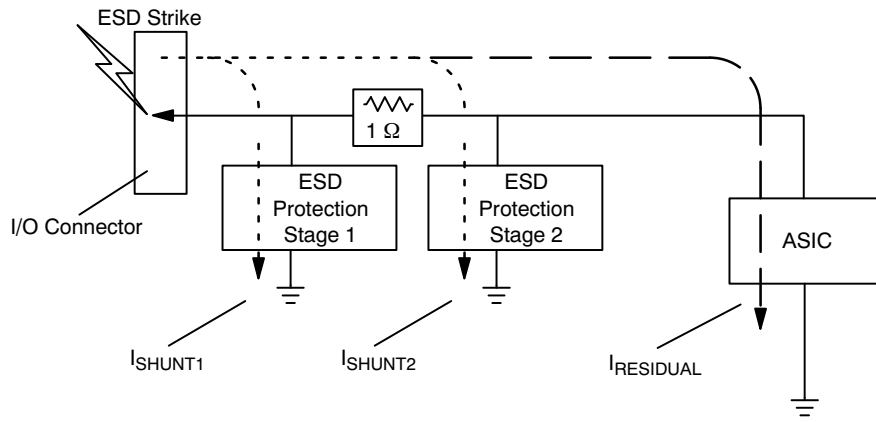

Figure 2. Dual Clamp ESD Protection Block Diagram

### CM1231-02SO ARCHITECTURE OVERVIEW

The PicoGuard XP™ two-stage per channel matched clamp architecture with isolated clamp rails features a series element to radically reduce the residual ESD current ( $I_{RES}$ ) that enters the ASIC under protection (see Figure 3). From stage 1 to stage 2, the signal lines go through matched dual  $1\ \Omega$  resistors.

The function of the series element (dual  $1\ \Omega$  resistors for the CM1231-02SO) is to optimize the operation of the stage two diodes to reduce the final  $I_{RES}$  current to a minimum while maintaining an acceptable insertion impedance that is negligible for the associated signaling levels.

Each stage consists of a traditional low-cap Dual Rail Clamp structure which steer the positive or negative ESD

current pulse to either the positive ( $V_P$ ) or negative ( $V_N$ ) supply rail.

A zener diode is embedded between  $V_P$  and  $V_N$ , offering two advantages. First, it protects the  $V_{CC}$  rail against ESD strikes. Second, it eliminates the need for an additional bypass capacitor to shunt the positive ESD strikes to ground.

The CM1231-02SO therefore replaces as many as seven discrete components, while taking advantage of precision internal component matching for improved signal integrity, which is not otherwise possible with discrete components at the system level.

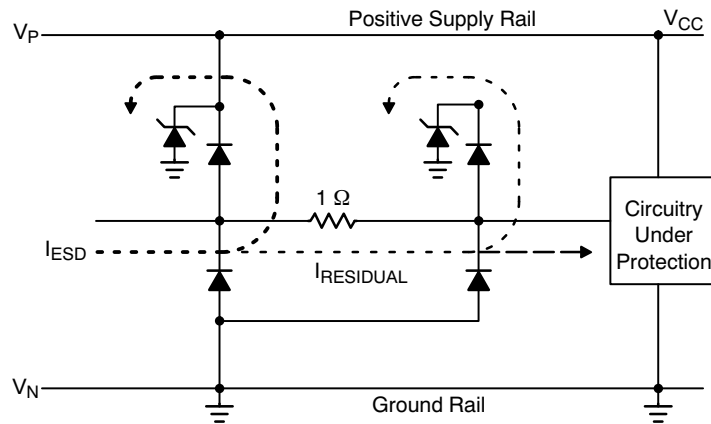

Figure 3. CM1231-02SO Block Diagram ( $I_{ESD}$  Flow During a Positive Strike)

## CM1231-02SO

### Advantages of the CM1231-02SO Dual Stage ESD Protection Architecture

Figure 4 illustrates a single stage ESD protection device. The inductor element represents the parasitic inductance arising from the bond wire and the PCB trace leading to the ESD protection diodes.

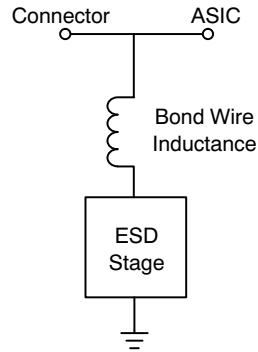

Figure 4. Single Stage ESD Protection Model

Figure 5 illustrates one of the two CM1231-02SO channels. Similarly, the inductor elements represent the parasitic inductance arising from the bond wire and PCB traces leading to the ESD protection diodes as well.

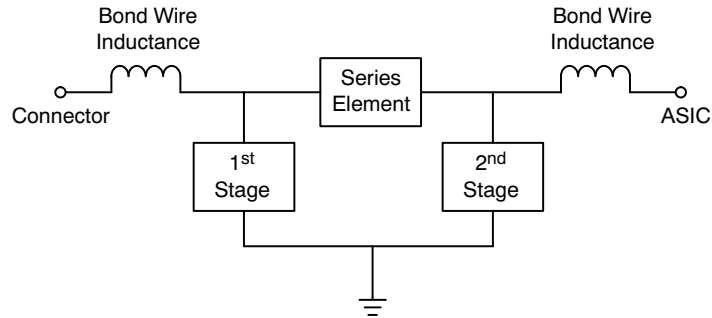

Figure 5. CM1231-02SO Dual Stage ESD Protection Model

### CM1231-02SO Inductor Elements

In the CM1231-02SO dual stage *PicoGuard XP*<sup>™</sup> architecture, the inductor elements and ESD protection diodes interact differently compared to the single stage model.

In the single stage model, the inductive element presents high impedance at high frequency, i.e. during an ESD strike. The impedance increases the resistance of the conduction path leading to the ESD protection element. This limits the speed that the ESD pulse can discharge through the single stage protection element.

In the *PicoGuard XP*<sup>™</sup> architecture, the inductance elements are in series to the conduction path leading to the protected device. The elements actually help to limit the current and voltage striking the protected device.

The reactance of the series and the inductor elements in the second stage forces more of the ESD strike current to be

shunted through the first stage. At the same time the voltage drop across series element helps to lower the clamping voltage at the protected terminal.

The inductor elements also tune the impedance of the stage by cancelling the capacitive load presented by the ESD diodes to the signal line. This improves the signal integrity and makes the ESD protection stages more transparent to the high bandwidth data signals passing through the channel.

The innovative *PicoGuard XP*<sup>™</sup> architecture turns the disadvantages of the parasitic inductive elements into useful components that help to limit the ESD current strike to the protected device and also improves the signal integrity of the system by balancing the capacitive loading effects of the ESD diodes.

# CM1231-02SO

## GRAPHICAL COMPARISON AND TEST SETUP

The following graphs (see Figure 6, Figure 7 and Figure 8) show that the CM1231-02SO (dual stage ESD protector) lowers the peak voltage and clamping voltage by 40% across a wide range of loading conditions in comparison to a standard single stage device. This data was derived using the test setups shown in Figure 9 and Figure 10.

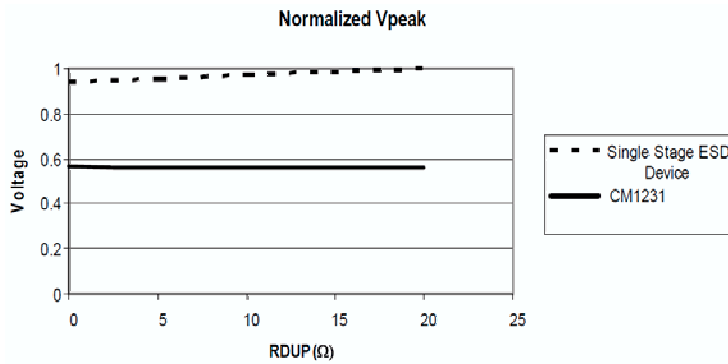

Figure 6. IEC 61000-4-2 V<sub>peak</sub> vs. Loading (RDUP\*)

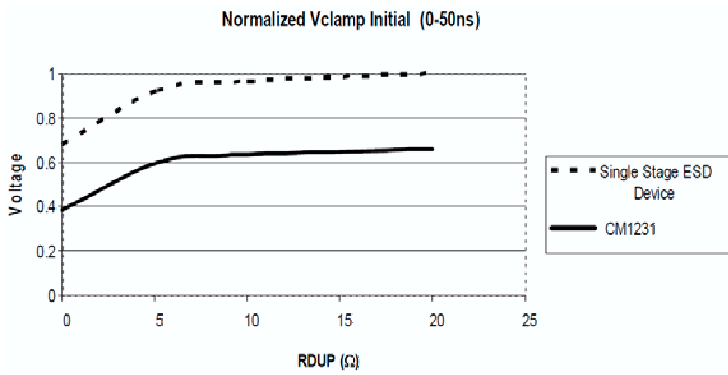

Figure 7. IEC 61000-4-2 V<sub>clamp</sub> vs. Loading (RDUP\*)

\*RDUP indicates the amount of Resistance (load) supplied to the Device Under Protection (DUP) through a variable resistor.

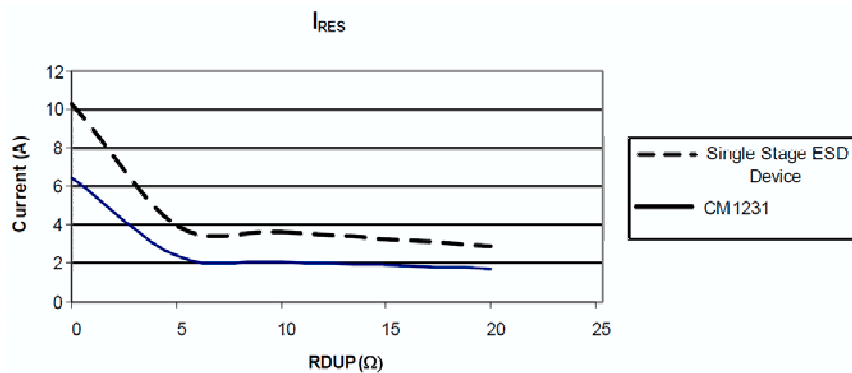

Figure 8. IEC 61000-4-2 I<sub>RES</sub> (Residual ESD Peak Current) vs. Loading (RDUP)

# CM1231-02SO

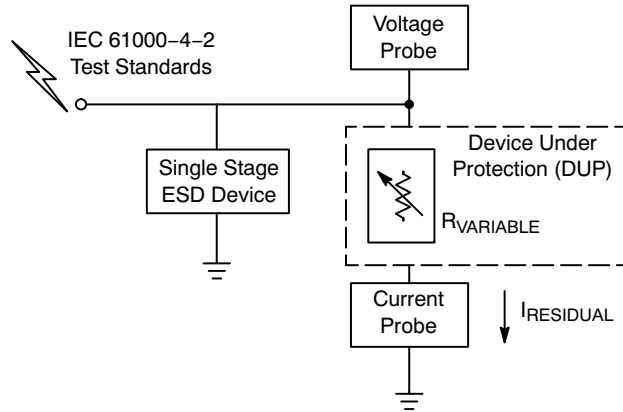

Figure 9. Single Stage ESD Device Test Setup

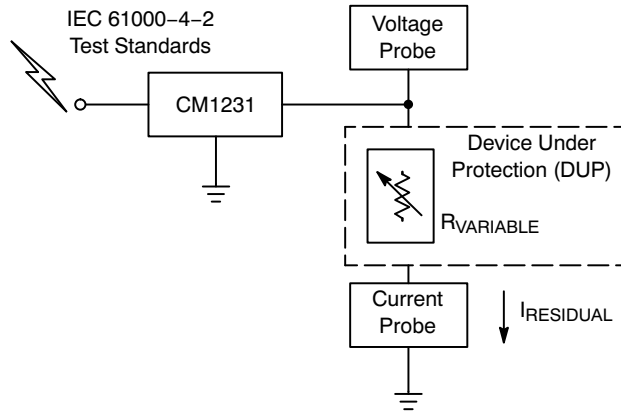
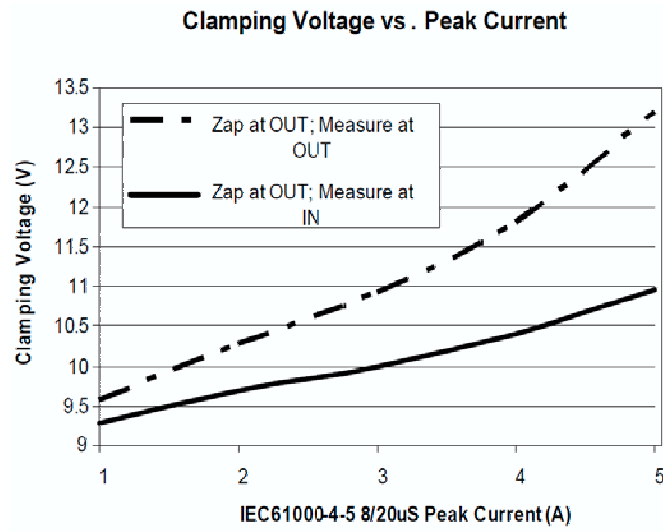

Figure 10. CM1231-02SO Test Setup



# CM1231-02SO

## PERFORMANCE INFORMATION



**Figure 11. Clamping Voltage vs. Peak Current**

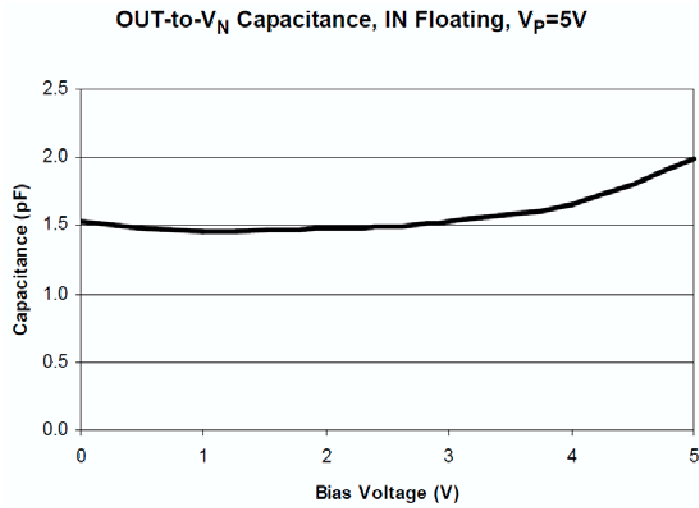

**Figure 12. Capacitance vs. Bias Voltage**

# CM1231-02SO

## PERFORMANCE INFORMATION (Cont'd)

Typical Filter Performance (Nominal Conditions unless Specified Otherwise, 0 V DC bias, 50  $\Omega$  Environment)

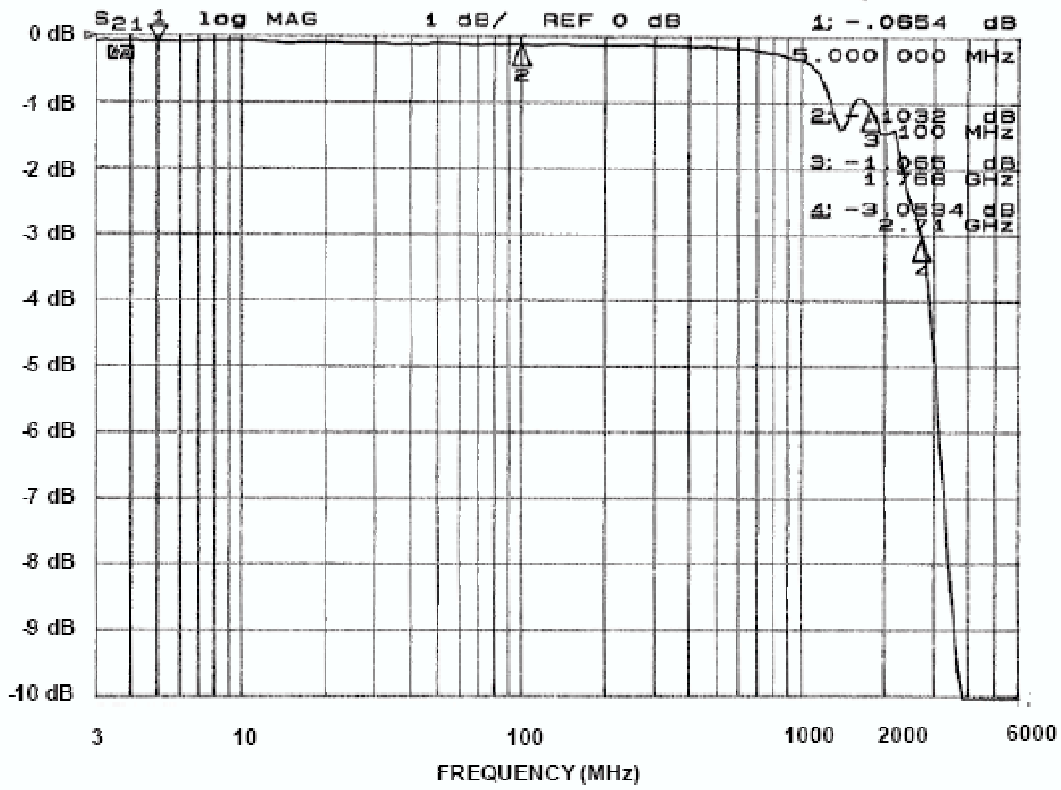

Figure 13. Typical Single-Ended  $S_{21}$  Plot (1 dB/div, 3 MHz to 6 GHz)

# CM1231-02SO

## APPLICATION INFORMATION

### CM1231-02SO Application and Guidelines

The CM1231-02SO has an integrated zener diode between  $V_P$  and  $V_N$  (for each of the two stages). This greatly reduces the effect of supply rail inductance  $L_2$  on  $V_{CL}$  by clamping  $V_P$  at the breakdown voltage of the zener diode. However, for the lowest possible  $V_{CL}$ , especially when  $V_P$  is biased at a voltage significantly below the zener breakdown voltage, it is recommended that a 0.22  $\mu\text{F}$  ceramic chip capacitor be connected between  $V_P$  and the ground plane.

With the CM1231-02SO, this additional bypass capacitor is generally not required.

As a general rule, the ESD Protection Array should be located as close as possible to the point of entry of expected electrostatic discharges. The power supply bypass capacitor mentioned above should be as close to the  $V_P$  pin of the Protection Array as possible, with minimum PCB trace lengths to the power supply, ground planes and between the signal input and the ESD device to minimize stray series inductance.

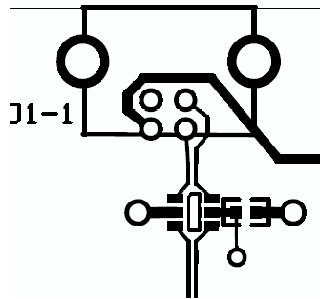

Figure 14. Typical Layout with Optional  $V_P$  Cap Footprint

### Additional Information

See also ON Semiconductor Application Note, “Design Considerations for ESD Protection,” in the Applications section.

# CM1231-02SO

## PACKAGE DIMENSIONS

SOT-23, 6 Lead  
CASE 527AJ-01  
ISSUE A

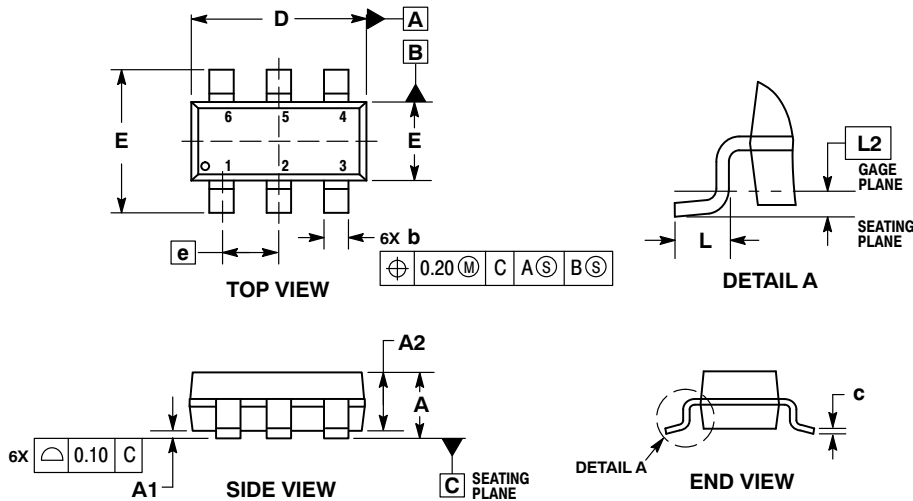

- NOTES:
1. DIMENSIONING AND TOLERANCING PER ASME Y14.5M, 1994.
  2. CONTROLLING DIMENSION: MILLIMETERS.
  3. DATUM C IS THE SEATING PLANE.

MILLIMETERS		
DIM	MIN	MAX
A	---	1.45
A1	0.00	0.15
A2	0.90	1.30
b	0.20	0.50
c	0.08	0.26
D	2.70	3.00
E	2.50	3.10
E1	1.30	1.80
e	0.95 BSC	
L	0.20	0.60
L2	0.25 BSC	

### RECOMMENDED SOLDERING FOOTPRINT\*

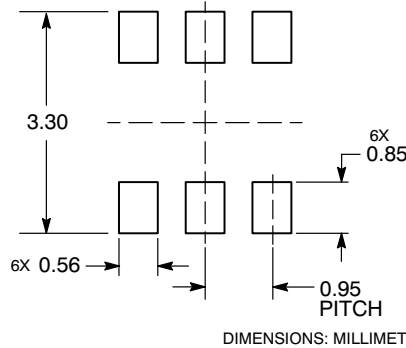

\*For additional information on our Pb-Free strategy and soldering details, please download the ON Semiconductor Soldering and Mounting Techniques Reference Manual, SOLDERRM/D.

PicoGuard XP is a trademark of Semiconductor Components Industries, LLC (SCILLC).

ON Semiconductor and  are registered trademarks of Semiconductor Components Industries, LLC (SCILLC). SCILLC reserves the right to make changes without further notice to any products herein. SCILLC makes no warranty, representation or guarantee regarding the suitability of its products for any particular purpose, nor does SCILLC assume any liability arising out of the application or use of any product or circuit, and specifically disclaims any and all liability, including without limitation special, consequential or incidental damages. "Typical" parameters which may be provided in SCILLC data sheets and/or specifications can and do vary in different applications and actual performance may vary over time. All operating parameters, including "Typicals" must be validated for each customer application by customer's technical experts. SCILLC does not convey any license under its patent rights nor the rights of others. SCILLC products are not designed, intended, or authorized for use as components in systems intended for surgical implant into the body, or other applications intended to support or sustain life, or for any other application in which the failure of the SCILLC product could create a situation where personal injury or death may occur. Should Buyer purchase or use SCILLC products for any such unintended or unauthorized application, Buyer shall indemnify and hold SCILLC and its officers, employees, subsidiaries, affiliates, and distributors harmless against all claims, costs, damages, and expenses, and reasonable attorney fees arising out of, directly or indirectly, any claim of personal injury or death associated with such unintended or unauthorized use, even if such claim alleges that SCILLC was negligent regarding the design or manufacture of the part. SCILLC is an Equal Opportunity/Affirmative Action Employer. This literature is subject to all applicable copyright laws and is not for resale in any manner.

### PUBLICATION ORDERING INFORMATION

**LITERATURE FULFILLMENT:**  
Literature Distribution Center for ON Semiconductor  
P.O. Box 5163, Denver, Colorado 80217 USA  
Phone: 303-675-2175 or 800-344-3860 Toll Free USA/Canada  
Fax: 303-675-2176 or 800-344-3867 Toll Free USA/Canada  
Email: orderlit@onsemi.com

**N. American Technical Support:** 800-282-9855 Toll Free USA/Canada  
**Europe, Middle East and Africa Technical Support:**  
Phone: 421 33 790 2910  
**Japan Customer Focus Center**  
Phone: 81-3-5773-3850

**ON Semiconductor Website:** [www.onsemi.com](http://www.onsemi.com)  
**Order Literature:** <http://www.onsemi.com/orderlit>  
For additional information, please contact your local Sales Representative