

# SB2020CT THRU SB20200CT

## List

List..... 1

Package outline..... 2

Features..... 2

Mechanical data..... 2

Maximum ratings .....2

Rating and characteristic curves..... 3

Pinning information.....4

Marking..... 4

Tube packing.....4

Suggested thermal profiles for soldering processes..... 5

High reliability test capabilities.....6

# SB2020CT THRU SB20200CT

## 20A Power Schottky Barrier Rectifiers - 20V-200V

### Features

- For use in low voltage, high frequency inverters, free wheeling, and polarity protection applications
- Offer 10A half wave and 20A full wave rectification.
- Low power loss, high efficiency.
- High current capability, low forward voltage drop.
- High surge capability.
- Guardring for overvoltage protection.
- Ultra high-speed switching.
- Silicon epitaxial planar chip, metal silicon junction.
- Lead-free parts meet environmental standards of MIL-STD-19500 / 228
- Suffix "-H" indicates Halogen-free parts, ex. SB2020CT-H.

### Mechanical data

- Epoxy : UL94-V0 rated flame retardant
- Case : JEDEC TO-220AB molded plastic body over passivated chip
- Lead : Axial leads, solderable per MIL-STD-202, Method 208 guaranteed
- Polarity: As marked
- Mounting Position : Any
- Weight : Approximated 2.10 gram

### Package outline

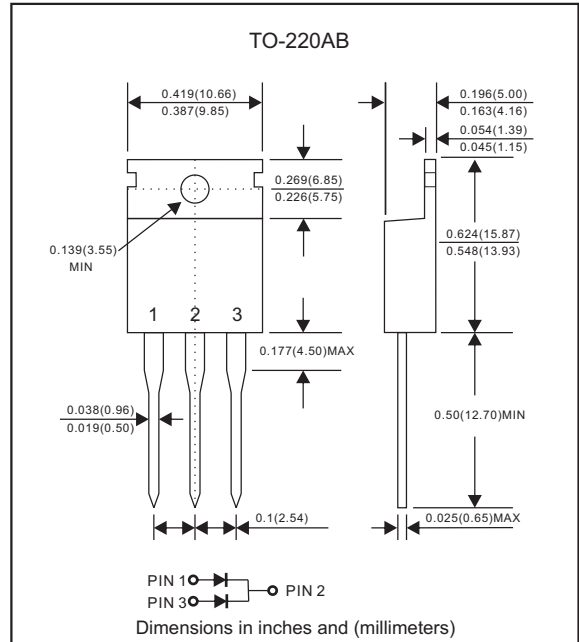

### Maximum ratings (AT $T_A=25^\circ\text{C}$ unless otherwise noted)

PARAMETER	SYMBOLS	SB 2020CT	SB 2040CT	SB 2045CT	SB 2050CT	SB 2060CT	SB 2080CT	SB 20100CT	SB 20150CT	SB 20200CT	UNIT
Maximum repetitive peak reverse voltage	V <sub>RRM</sub>	20	40	45	50	60	80	100	150	200	V
Maximum RMS voltage	V <sub>RMS</sub>	14	28	31.5	35	42	56	70	105	140	V
Maximum DC blocking voltage	V <sub>DC</sub>	20	40	45	50	60	80	100	150	200	V
Maximum average forward rectified current	I <sub>O</sub>	20									A
Peak forward surge current 8.3ms single half sine-wave (JEDEC method)	I <sub>FSM</sub>	200									A
Operating junction temperature range	T <sub>J</sub>	-55 to +125			-55 to +150						°C
Storage temperature range	T <sub>STG</sub>	-65 to +175									°C

### Electrical Characteristics (AT $T_A=25^\circ\text{C}$ unless otherwise noted)

PARAMETER	SYMBOLS	SB 2020CT	SB 2040CT	SB 2045CT	SB 2050CT	SB 2060CT	SB 2080CT	SB 20100CT	SB 20150CT	SB 20200CT	UNIT	
Maximum forward voltage per leg at I <sub>F</sub> =10A	V <sub>F</sub>	0.55			0.75		0.85		0.90	0.92	V	
Maximum DC reverse current at T <sub>J</sub> =25°C at rated DC blocking voltage per leg	I <sub>R</sub>	0.5					50					mA mA

### Thermal Characteristics

PARAMETER	SYMBOLS	SB 2020CT	SB 2040CT	SB 2045CT	SB 2050CT	SB 2060CT	SB 2080CT	SB 20100CT	SB 20150CT	SB 20200CT	UNIT
Typical thermal resistance junction to case per leg	R <sub>θJC</sub>	2.0									°C/W

## Rating and characteristic curves (SB2020CT THRU SB20200CT)

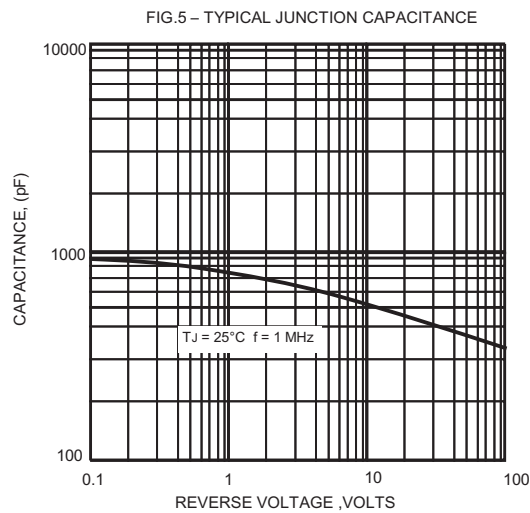
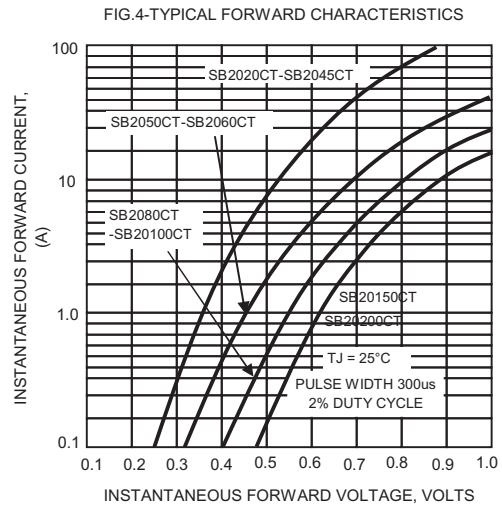
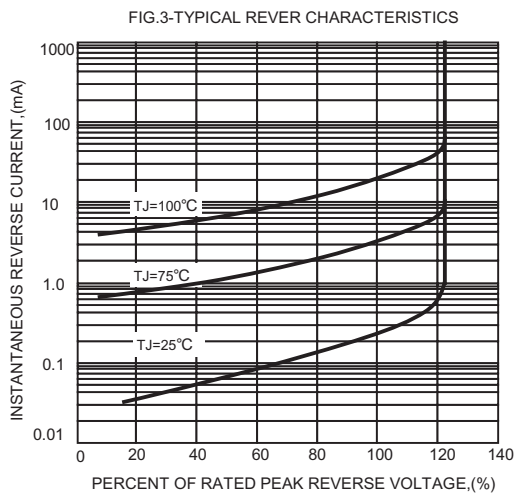
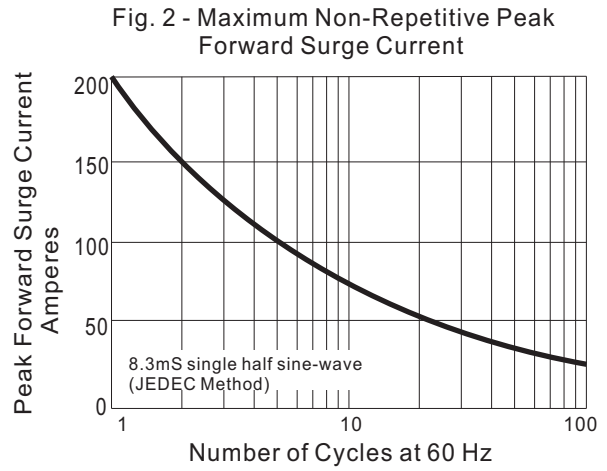
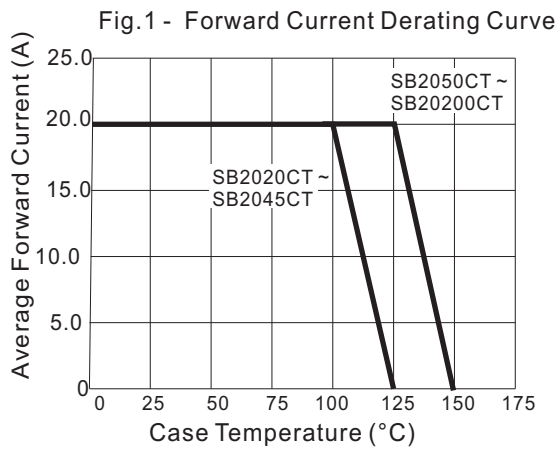

**SB2020CT THRU SB20200CT****Pinning information**

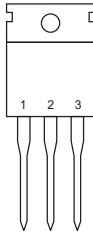
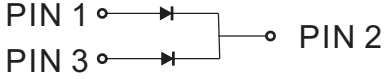
Pin	Simplified outline	Symbol
Pin1 anode Pin2 cathode Pin3 anode		

**Marking**

Type number	Marking code
SB2020CT	SB2020CT
SB2040CT	SB2040CT
SB2045CT	SB2045CT
SB2050CT	SB2050CT
SB2060CT	SB2060CT
SB2080CT	SB2080CT
SB20100CT	SB20100CT
SB20150CT	SB20150CT
SB20200CT	SB20200CT

**Tube packing**

PACKAGE	TUBE (pcs)	TUBE SIZE (m/m)	BOX (pcs)	INNER BOX (m/m)	CARTON SIZE (m/m)	CARTON (pcs)	APPROX. GROSS WEIGHT (kg)
TO-220AB	50	525*32*7.5	1000	555*150*40	580*230*175	5,000	15.0

# SB2020CT THRU SB20200CT

## Suggested thermal profiles for soldering processes

### 1. Lead free temperature profile wave-soldering

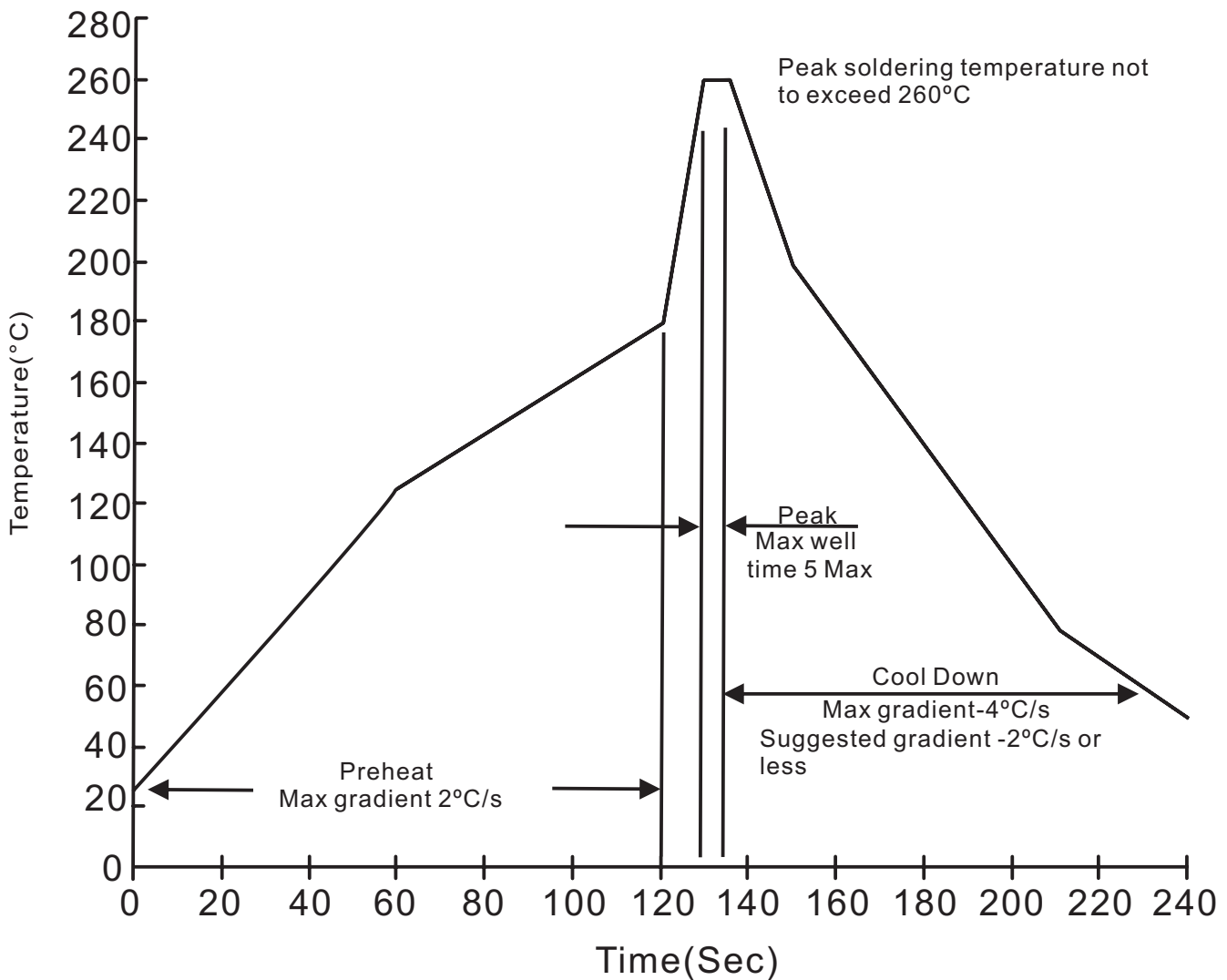

**SB2020CT THRU SB20200CT****High reliability test capabilities**

Item Test	Conditions	Reference
1. Solder Resistance	at $260\pm 5^{\circ}\text{C}$ for $10\pm 2\text{sec}$ . immerse body into solder $1/16''\pm 1/32''$	MIL-STD-750D METHOD-2031
2. Solderability	at $245\pm 5^{\circ}\text{C}$ for 5 sec.	MIL-STD-202F METHOD-208
3. High Temperature Reverse Bias	$V_R=80\%$ rate at $T_J=125^{\circ}\text{C}$ for 168 hrs.	MIL-STD-750D METHOD-1038
4. Forward Operation Life	Rated average rectifier current at $T_A=25^{\circ}\text{C}$ for 500hrs.	MIL-STD-750D METHOD-1027
5. Intermittent Operation Life	$T_A = 25^{\circ}\text{C}$ , $I_F = I_O$ On state: power on for 5 min. off state: power off for 5 min. on and off for 500 cycles.	MIL-STD-750D METHOD-1036
6. Pressure Cooker	$15P_{SIG}$ at $T_A=121^{\circ}\text{C}$ for 4 hrs.	JESD22-A102
7. Temperature Cycling	$-55^{\circ}\text{C}$ to $+125^{\circ}\text{C}$ dwelled for 30 min. and transferred for 5min. total 10 cycles.	MIL-STD-750D METHOD-1051
8. Forward Surge	8.3ms single half sine-wave , one surge.	MIL-STD-750D METHOD-4066-2
9. Humidity	at $T_A=85^{\circ}\text{C}$ , RH=85% for 1000hrs.	MIL-STD-750D METHOD-1021
10. High Temperature Storage Life	at $175^{\circ}\text{C}$ for 1000 hrs.	MIL-STD-750D METHOD-1031