

HOW TO ORDER

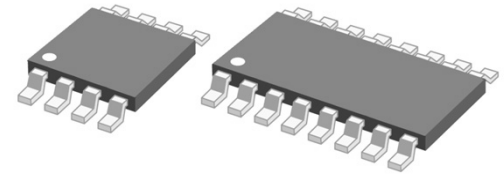
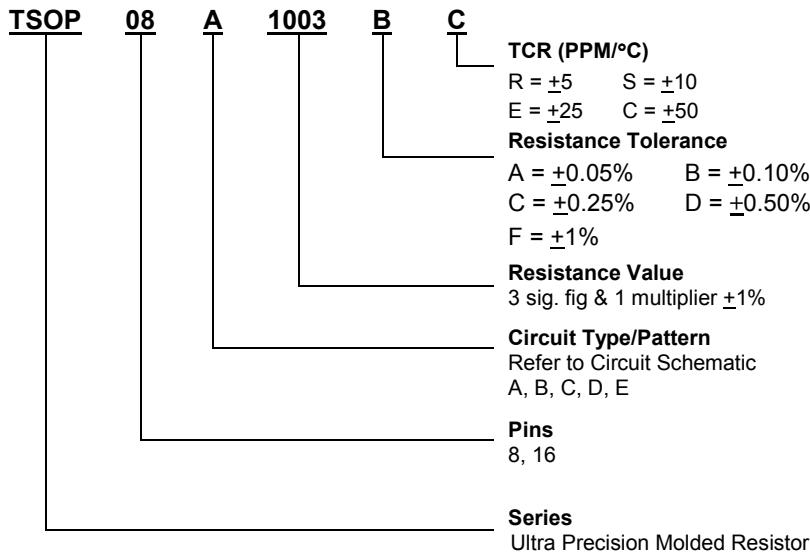

FEATURES

- TSOP High Precision NiCr Thin Film Resistor Networks with tight ratio and tracking
- 10 Standard Circuits
- Tight Tracking T.C.R to 1 PPM
- High Stability Thin Film
- 2.3mm High from PC Board, most fit for high density compacted instruments.
- Custom Circuit Configuration is Available

ELECTRICAL SPECIFICATIONS

Rated Power per Resistor at 70°C	60mW
Maximum Working Voltage	75V
Maximum Overload Voltage	150V
Absolute TCR ppm/°C	50, 25, 10, 5
Absolute Tolerance %	0.25, 0.1, 0.05

MECHANICAL SPECIFICATIONS

Mechanical Protection	Epoxy Molded
Resistive Element	NiCr Film
Terminal Leads	Tinned

TSOP SCHEMATIC

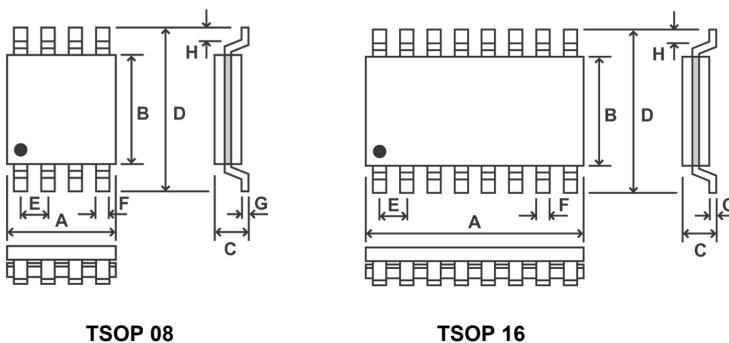

TYPICAL PERFORMANCE

TCR	ABS	TRACKING
	$\pm 5\text{ppm}$	1, 2, 3, 5
	$\pm 10\text{ppm}$	1, 2, 3, 5, 10
	$\pm 25\text{ppm}$	1, 2, 3, 5, 10
	$\pm 50\text{ppm}$	1, 2, 3, 5, 10

TOL.	ABS	RATIO
	$\pm 0.05\%$	0.025, 0.05, 0.1
	$\pm 0.10\%$	0.025, 0.05, 0.1, 0.2
	$\pm 0.25\%$	0.025, 0.05, 0.1, 0.25, 0.5
	$\pm 0.5\%$	0.25, 0.1, 0.05
	$\pm 1\%$	0.5, 0.25, 0.1, 0.05

DIMENSIONS (mm)

Model	A	B	C	D	E	F	G	H
TSOP 08	5.5 ± 0.3	5.3 ± 0.3	2.3 max	8.0 ± 0.2	1.27 ± 0.2	0.4 ± 0.05	0.2 ± 0.1	0.3 min
TSOP 16	10.5 ± 0.5	5.3 ± 0.3	2.3 max	8.0 ± 0.2	1.27 ± 0.2	0.4 ± 0.05	0.2 ± 0.1	0.3 min

CIRCUIT SPECIFICATION

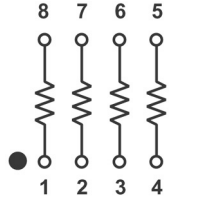
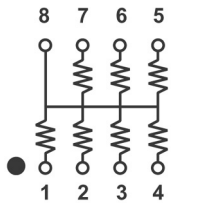
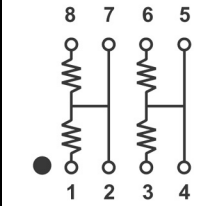
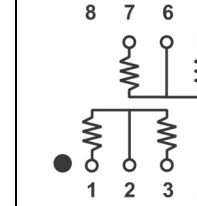
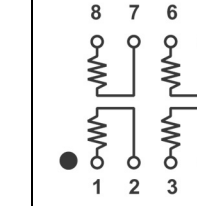
Circuit Symbol	A	B	C	D	E
TSOP 08 Circuit Layout Options					
Resistance Range (Ω)	50.0 ~ 22.0K	50.0 ~ 10.0K	50.0 ~ 22.0K	50.0 ~ 22K	500 ~ 10.0K

CIRCUIT SPECIFICATION – 16 PINS

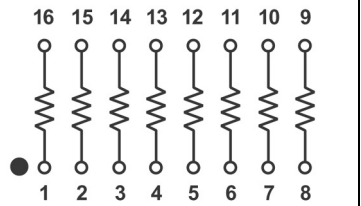
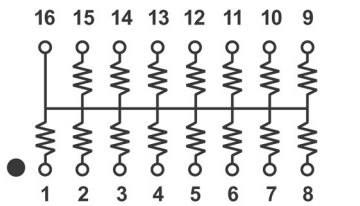
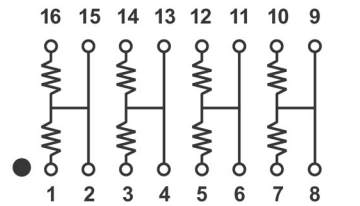
Circuit Symbol	A	B	C
TSOP 16 Circuit Layout Options			
Resistance Range (Ω)	50.0 ~ 22.0K	50.0 ~ 10.0K	50.0 ~ 22.0K

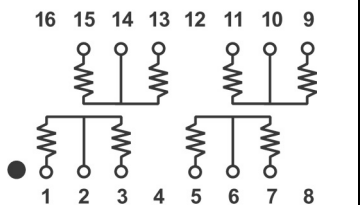
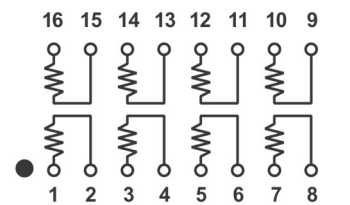
Circuit Symbol	D	E
TSOP 16 Circuit Layout Options		
Resistance Range (Ω)	50.0 ~ 22K	500 ~ 10.0K

PERFORMANCE

TEST	TEST METHOD	REQUIREMENTS
Operating Temperature Range		-55°C ~ 155°C
Short Time Overload	2.5 x rated voltage for 5 seconds	$\pm (0.1\% + 0.05\Omega)$
Temperature Cycle	-55°C ~ 155°C for 5 cycles	$\pm (0.1\% + 0.05\Omega)$
Resistance to Solder Heat	260°C \pm 5°C for 10 seconds	$\pm (0.05\% + 0.05\Omega)$
Moisture Resistance Load Life	40°C, 90 ~ 95% R.H. rated voltage, 1,000 hours	$\pm (0.1\% + 0.05\Omega)$
Load Life at 70°C	70°C, rated voltage, 1.5 hours on, 0.5 hours off, 1,000 hours	$\pm (0.1\% + 0.05\Omega)$

The content of this specification may change without notification 5/15/2015