

Off-Line Digital Green-Mode Quasi-Resonant PWM Controller

1 Description

The iW1679 is a high performance AC/DC power supply controller that uses digital control technology to build peak current mode PWM flyback power supplies. The device directly drives a power BJT and operates in quasi-resonant mode to provide high efficiency and key built-in protection features, while minimizing the external component count, simplifying EMI design, and lowering the total bill of material cost. The iW1679 removes the need for a secondary feedback circuit while achieving excellent line and load regulation. It also eliminates the need for loop compensation components while maintaining stability over all operating conditions. The pulse-by-pulse waveform analysis allows for fast dynamic load response for both one-time and repetitive load transients. The built-in power limit function enables optimized transformer design for a wide input voltage range.

Dialog's innovative proprietary technology ensures that power supplies built with the iW1679 can achieve both the highest average efficiency and less than 30mW no-load power consumption, and have fast dynamic load response in typical 5V/2A applications. The active start-up scheme enables the shortest possible start-up time without sacrificing no-load power loss.

2 Features

- No-load power consumption < 20mW at 230V_{AC} with typical application circuit (5-star rating)
- Optimized for 5V/2A AC/DC adapters/chargers with < 30mW no-load power consumption at 230V_{AC} and fast dynamic load response for both one-time and repetitive load transients
- Direct drive of low-cost BJT power switch
- Very tight constant voltage and constant current regulation over entire operating range
- **PrimAccurate**[™] primary-side feedback eliminates opto-isolators and simplifies design
- **EZ-EMI**[®] design enhances manufacturability
- Intrinsically low common mode noise
- Optimized 72kHz maximum PWM switching frequency achieves best size and efficiency
- Adaptive multi-mode PWM/PFM control improves efficiency
- Quasi-resonant operation for highest overall efficiency
- Dynamic base current control
- No external loop compensation components required
- Complies with EPA 2.0/CoC Ver5/DoE energy-efficiency specifications with ample margin
- Built-in protections for output short-circuit, output low impedance, and output overvoltage
- Built-in over-temperature protection (OTP)
- No audible noise over entire operating range

3 Applications

- Compact AC/DC adapters/chargers for media tablets and smart phones
- AC/DC adapters for consumer electronics

Off-Line Digital Green-Mode Quasi-Resonant PWM Controller

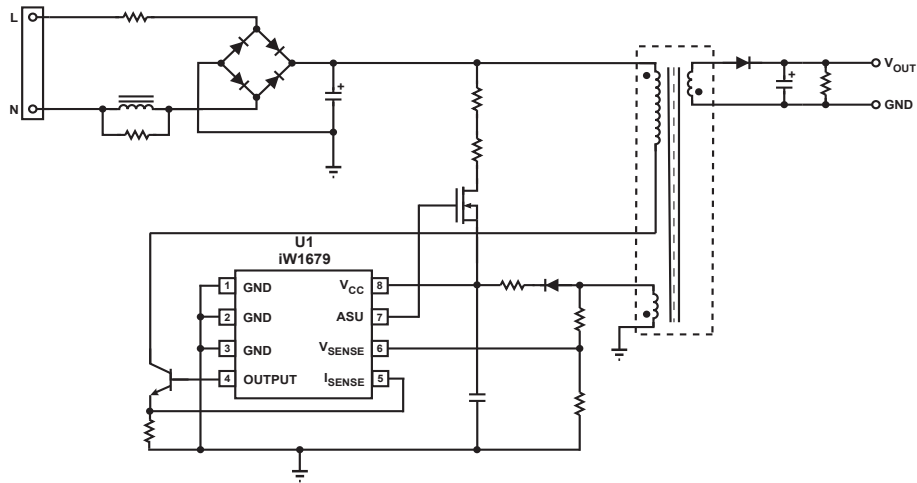

Figure 3.1 : iW1679 Typical Application Circuit
 (Achieving < 30mW No-load Power Consumption. Using Depletion Mode NFET as Active Start-up Device)

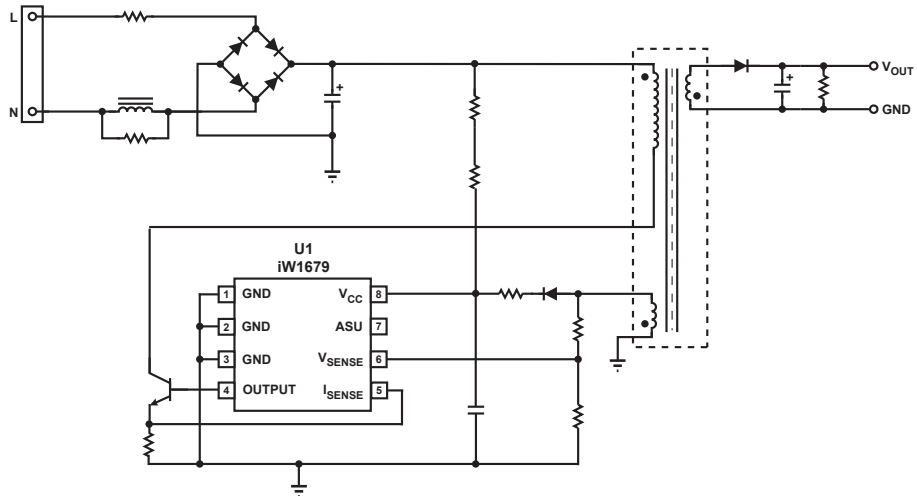

Figure 3.2: iW1679 Typical Application Circuit
 (Achieving < 50mW No-load Power Consumption. Alternative Circuit without Using Active Start-up Device)

Off-Line Digital Green-Mode Quasi-Resonant PWM Controller

4 Pinout Description

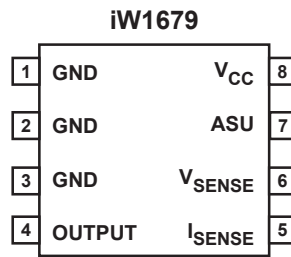

Figure 4.1 : 8-Lead SOIC Package

| Pin # | Name | Type | Pin Description |
|-------|-------------|--------------|--|
| 1 | GND | Ground | Ground. |
| 2 | GND | Ground | Ground. |
| 3 | GND | Ground | Ground. |
| 4 | OUTPUT | Output | Base drive for BJT. |
| 5 | I_{SENSE} | Analog Input | Primary current sense. It is used for cycle-by-cycle peak current control and limit. |
| 6 | V_{SENSE} | Analog Input | Auxiliary voltage sense. It is used for primary regulation. |
| 7 | ASU | Output | Control signal for active start-up device (BJT or Depletion NFET). |
| 8 | V_{CC} | Power Input | IC power supply. |

Off-Line Digital Green-Mode Quasi-Resonant PWM Controller

5 Absolute Maximum Ratings

Absolute maximum ratings are the parameter values or ranges which can cause permanent damage if exceeded. For maximum safe operating conditions, refer to Electrical Characteristics in Section 6.

| Parameter | Symbol | Value | Units |
|--|---------------|--------------|-------|
| DC supply voltage range (pin 8, $I_{CC} = 20\text{mA max}$) | V_{CC} | -0.3 to 25.0 | V |
| Continuous DC supply current at V_{CC} pin ($V_{CC} = 15\text{V}$) | I_{CC} | 25 | mA |
| ASU output (pin 7) | | -0.3 to 19.0 | V |
| Output (pin 4) | | -0.3 to 4.0 | V |
| V_{SENSE} input (pin 6, $I_{Vsense} \leq 10\text{mA}$) | | -0.7 to 4.0 | V |
| I_{SENSE} input (pin 5) | | -0.3 to 4.0 | V |
| Maximum junction temperature | T_{JMAX} | 150 | °C |
| Operating junction temperature | T_{JOPT} | -40 to 150 | °C |
| Storage temperature | T_{STG} | -65 to 150 | °C |
| Thermal resistance junction-to-ambient | θ_{JA} | 135 | °C/W |
| ESD rating per JEDEC JESD22-A114 | | $\pm 2,000$ | V |
| Latch-up test per JESD78D | | ± 100 | mA |

Off-Line Digital Green-Mode Quasi-Resonant PWM Controller

6 Physical Dimensions

8-Lead Small Outline (SOIC) Package

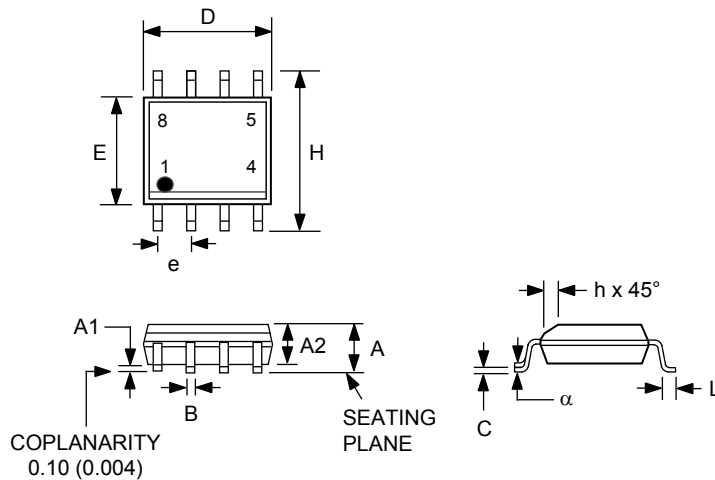

| Symbol | Inches | | Millimeters | |
|----------|-----------|-------|-------------|------|
| | MIN | MAX | MIN | MAX |
| A | 0.053 | 0.069 | 1.35 | 1.75 |
| A1 | 0.0040 | 0.010 | 0.10 | 0.25 |
| A2 | 0.049 | 0.059 | 1.25 | 1.50 |
| B | 0.014 | 0.019 | 0.35 | 0.49 |
| C | 0.007 | 0.010 | 0.19 | 0.25 |
| D | 0.189 | 0.197 | 4.80 | 5.00 |
| E | 0.150 | 0.157 | 3.80 | 4.00 |
| e | 0.050 BSC | | 1.27 BSC | |
| H | 0.228 | 0.244 | 5.80 | 6.20 |
| h | 0.10 | 0.020 | 0.25 | 0.50 |
| L | 0.016 | 0.049 | 0.4 | 1.25 |
| α | 0° | 8° | | |

Compliant to JEDEC Standard MS12F

Controlling dimensions are in inches; millimeter dimensions are for reference only

This product is RoHS compliant and Halide free.

Soldering Temperature Resistance:

[a] Package is IPC/JEDEC Std 020D moisture sensitivity level 1

[b] Package exceeds JEDEC Std No. 22-A111 for solder immersion resistance; package can withstand 10 s immersion < 260°C

Dimension D does not include mold flash, protrusions or gate burrs. Mold flash, protrusions or gate burrs shall not exceed 0.15 mm per end. Dimension E1 does not include interlead flash or protrusion. Interlead flash or protrusion shall not exceed 0.25 mm per side.

The package top may be smaller than the package bottom. Dimensions D and E1 are determined at the outermost extremes of the plastic body exclusive of mold flash, tie bar burrs, gate burrs and interlead flash, but including any mismatch between the top and bottom of the plastic body.

7 Ordering Information

| Part Number | Options | Package | Description |
|-------------|--|---------|--------------------------|
| iW1679-35 | Cable Comp = 150mV, CC shutdown voltage = 3V | SOIC-8 | Tape & Reel ¹ |

Note 1: Tape & Reel packing quantity is 2,500/reel. Minimum ordering quantity is 2,500.

Off-Line Digital Green-Mode Quasi-Resonant PWM Controller

Disclaimer

Information in this document is believed to be accurate and reliable. However, Dialog Semiconductor does not give any representations or warranties, expressed or implied, as to the accuracy or completeness of such information. Dialog Semiconductor furthermore takes no responsibility whatsoever for the content in this document if provided by any information source outside of Dialog Semiconductor.

Dialog Semiconductor reserves the right to change without notice the information published in this document, including without limitation the specification and the design of the related semiconductor products, software and applications.

Applications, software, and semiconductor products described in this document are for illustrative purposes only. Dialog Semiconductor makes no representation or warranty that such applications, software and semiconductor products will be suitable for the specified use without further testing or modification. Unless otherwise agreed in writing, such testing or modification is the sole responsibility of the customer and Dialog Semiconductor excludes all liability in this respect.

Customer notes that nothing in this document may be construed as a license for customer to use the Dialog Semiconductor products, software and applications referred to in this document. Such license must be separately sought by customer with Dialog Semiconductor.

All use of Dialog Semiconductor products, software and applications referred to in this document are subject to [Dialog Semiconductor's Standard Terms and Conditions of Sale](#), available on the company website (www.dialog-semiconductor.com) unless otherwise stated.

Dialog and the Dialog logo are trademarks of Dialog Semiconductor plc or its subsidiaries. All other product or service names are the property of their respective owners.

© 2017 Dialog Semiconductor. All rights reserved.

RoHS Compliance

Dialog Semiconductor's suppliers certify that its products are in compliance with the requirements of Directive 2011/65/EU of the European Parliament on the restriction of the use of certain hazardous substances in electrical and electronic equipment. RoHS certificates from our suppliers are available on request.

Contacting Dialog Semiconductor

United Kingdom (Headquarters)
Dialog Semiconductor (UK) LTD
Phone: +44 1793 757700

Germany
Dialog Semiconductor GmbH
Phone: +49 7021 805-0

The Netherlands
Dialog Semiconductor B.V.
Phone: +31 73 640 8822

Email
info_pcbg@diasemi.com

North America
Dialog Semiconductor Inc.
Phone: +1 408 845 8500

Japan
Dialog Semiconductor K. K.
Phone: +81 3 5425 4567

Taiwan
Dialog Semiconductor Taiwan
Phone: +886 281 786 222

Web site:
www.dialog-semiconductor.com

Singapore
Dialog Semiconductor Singapore
Phone: +65 64 8499 29

Hong Kong
Dialog Semiconductor Hong Kong
Phone: +852 3769 5200

Korea
Dialog Semiconductor Korea
Phone: +82 2 3469 8200

China (Shenzhen)
Dialog Semiconductor China
Phone: +86 755 2981 3669

China (Shanghai)
Dialog Semiconductor China
Phone: +86 21 5424 9058