

DASH NO.	M CODE	MADE FROM
----------	--------	-----------

GSD

879-11-16 MA9

REVISIONS	
ISSUE	CHANGES
0	ER 9212 PW 01/13/71
1	CN 10314 CC 11/16/71
2	CN 18981 A MJB 12/29/78
3	CN 39626 C REDRAWN HVN 09/15/06

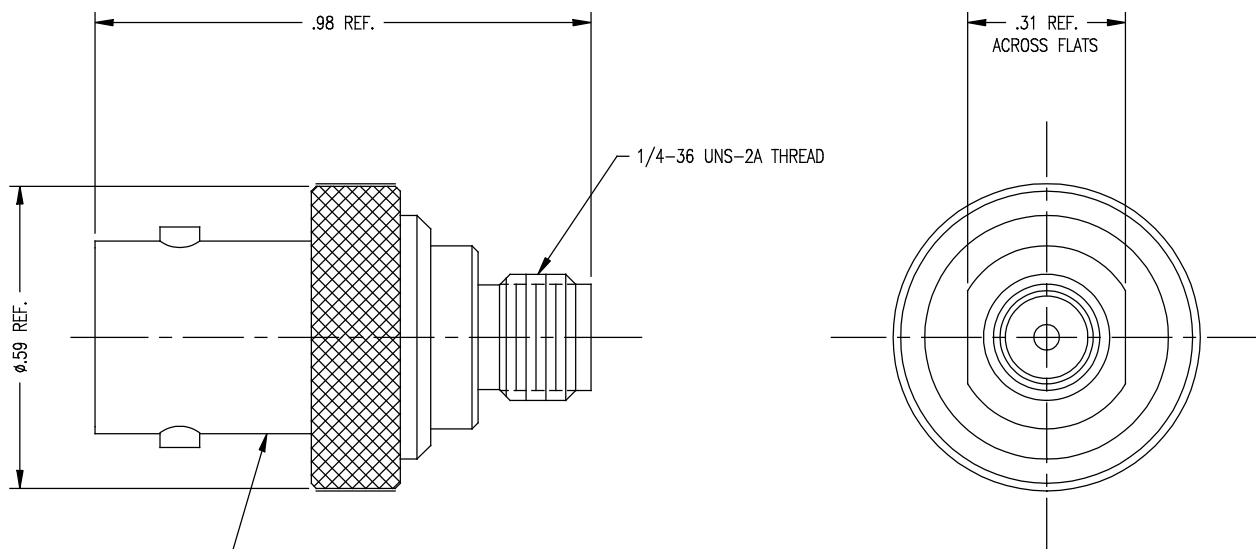

STAMP: KINGS 879-11-16 MA9  
YRWK (DATE CODE)

NOTES:

- MATERIALS:  
INSULATOR: TEFLON, ASTM-D-4894  
SMA BODY: STAINLESS STEEL, 303  
CENTER CONTACT: BER. COPPER, ASTM-B-196  
ALL OTHER METAL PARTS: BRASS, ASTM-B16
- FINISHES:  
ALL METAL PARTS: HARD GOLD PLATE PER ASTM-B-488
- ELECTRICAL CHARACTERISTICS:  
NOMINAL IMPEDANCE: 50 OHM  
VOLTAGE RATING: 500 VOLTS RMS  
FREQUENCY RANGE: DC TO 10 GHz

879-11-16 MA9 SD

SCALE 4 : 1	
APPROX SURFACE AREA	
USED ON	
REF:	
ADAPTER, BNC(F)-SMA(F)	
DRAWN H. NGUYEN	DATE 09/15/06
DESIGN PW	DATE 01/13/71
APPR.	DATE

**KINGS**  
ELECTRONICS CO., INC.  
ROCK HILL, SOUTH CAROLINA 29730

GSD

879-11-16 MA9