

## DETAILS

<b>Product Number</b>	CN14182_MIRELLA-50-XW-CL-PF-VERO10
<b>Family</b>	Mirella
<b>Type</b>	RefPack
<b>Color</b>	white
<b>Diameter</b>	50 mm
<b>Height</b>	23,9 mm
<b>Style</b>	round
<b>Optic Material</b>	HRPC
<b>Holder Material</b>	
<b>Fastening</b>	
<b>Status</b>	production ready
<b>ROHS Compliant</b>	Yes
<b>Date Updated</b>	2/11/2016



## OPTICAL PROPERTIES

LED	Viewing	Light	Effi-	cd/lm	Connector
	Angle	Beam	ciency		
VERO10	69 deg	WWW-class	87 %	0.600	-
Duris S8	76 deg	WWW-class	86 %	0.600	-

H G F E D C B A

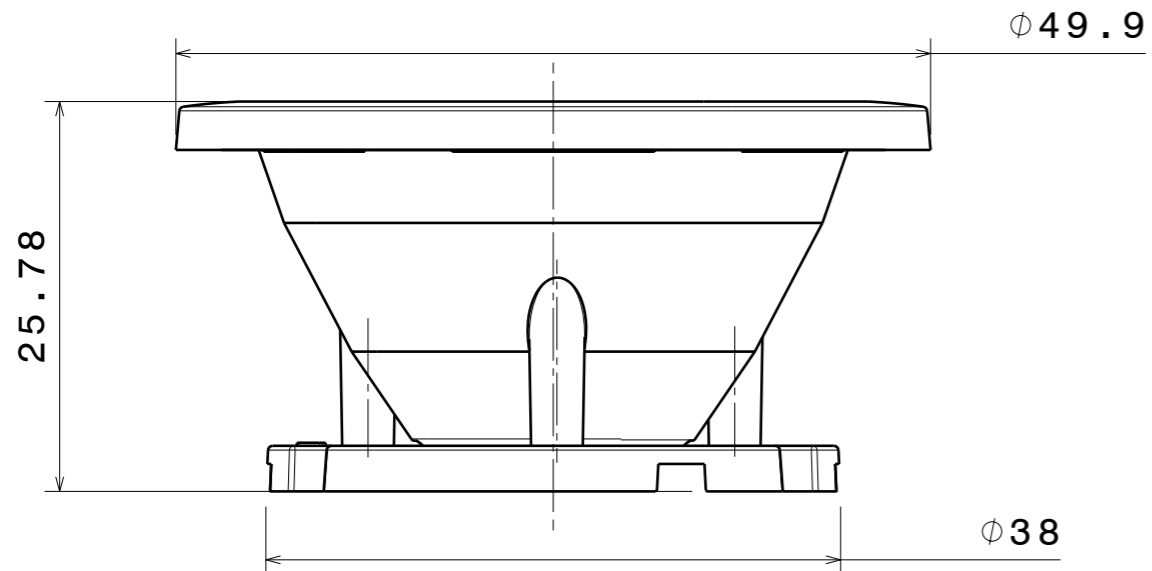

LED position

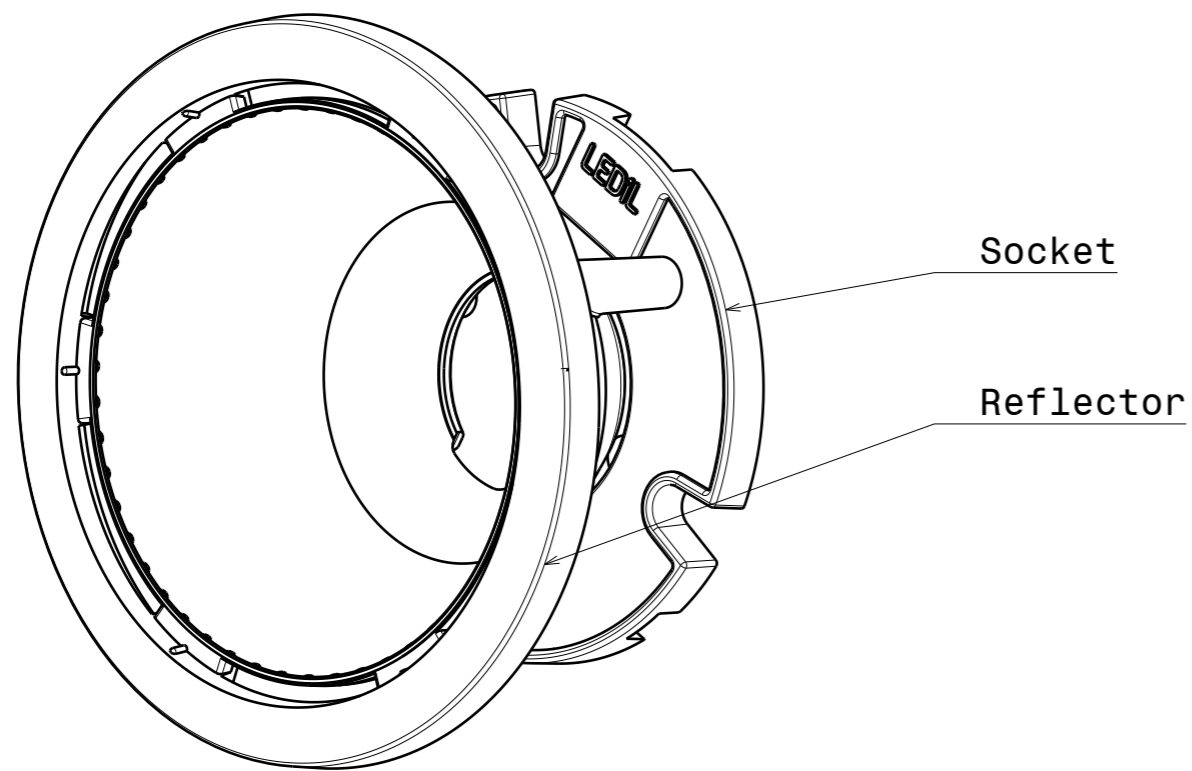
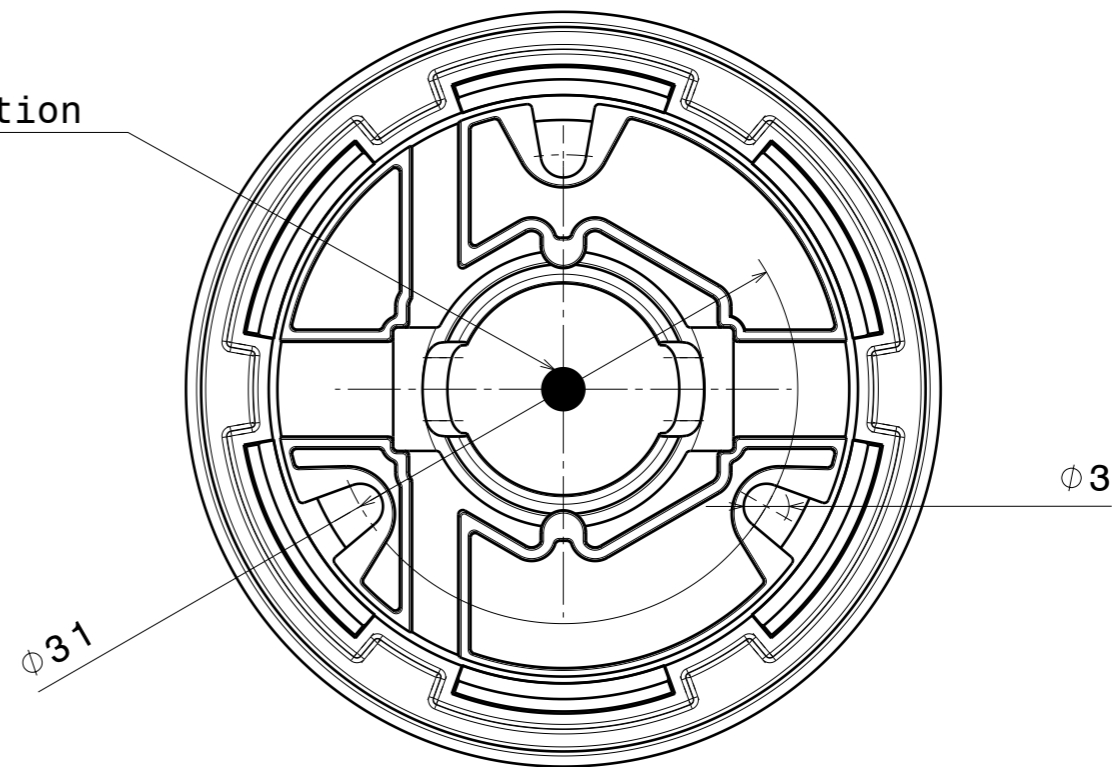

INDEX	PART NO	MATERIAL	COLOUR
1	Socket	PC	White
2	Reflector	PC	Metal

Tolerances if not otherwise shown  
 According to DIN ISO 2768-1  
 Linear measures:  
 up to 30mm class M, otherwise class C  
 According to DIN ISO 2768-2  
 Form and position: class L

**LEDiL** LediL Oy  
 Salorankatu 10  
 FIN 24240 SALO  
 Finland

THIRD ANGLE PROJECTION:

DRAWING TITLE  
**DATA SHEET MIRELLA-PF-SOCKET-VER010**

This drawing is the property of LEDiL Oy. It may not be reproduced, copied or communicated without a written agreement with LEDiL Oy.

SIZE PART NUMBER  
**A3** -

SCALE 2:1 WEIGHT - SHEET 1/1

NOTE: It is recommended to use glue like DELO-PUR 9895 for pin fastening.  
[http://www.delo.de/fileadmin/datasheet/DELO-PUR\\_9895\\_\(TIDB-GB\).pdf](http://www.delo.de/fileadmin/datasheet/DELO-PUR_9895_(TIDB-GB).pdf)

H G B A

Luminaire: LEDil Oy CN14182\_MIRELLA-50-XW-CL-PF-VERO10\_(Ostar\_Lighting+) Efficiency=86%  
Lamps: 1 x Osram Ostar Lighting+ (236lm @ 250mA) CCT=3100K P=3.2W I=250mA

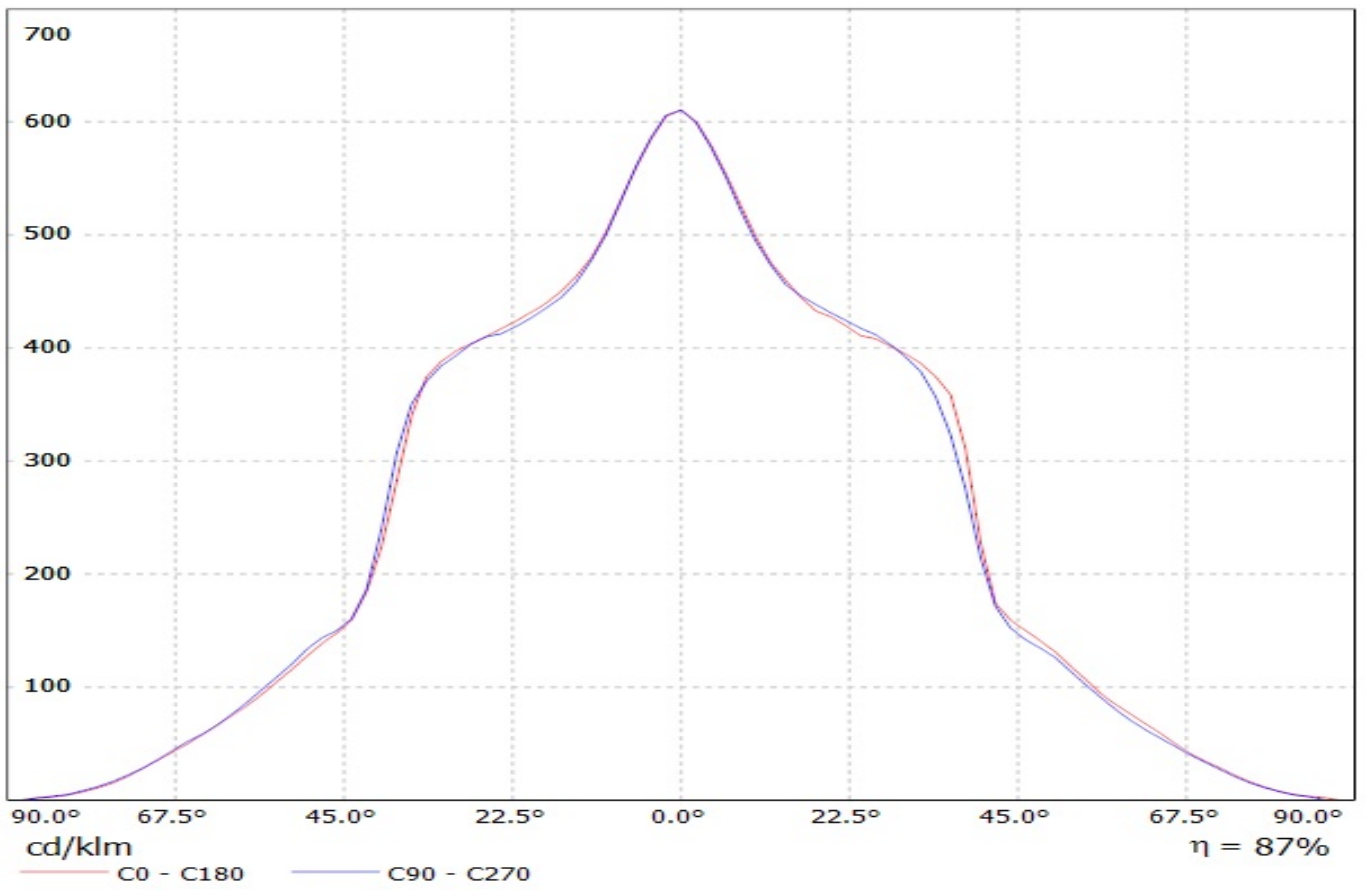

Luminaire: LEDil Oy CN14182\_MIRELLA-50-XW-CL-PF-VERO10\_(Ostar\_Lighting+) Efficiency=86%  
Lamps: 1 x Osram Ostar Lighting+ (236lm @ 250mA) CCT=3100K P=3.2W I=250mA

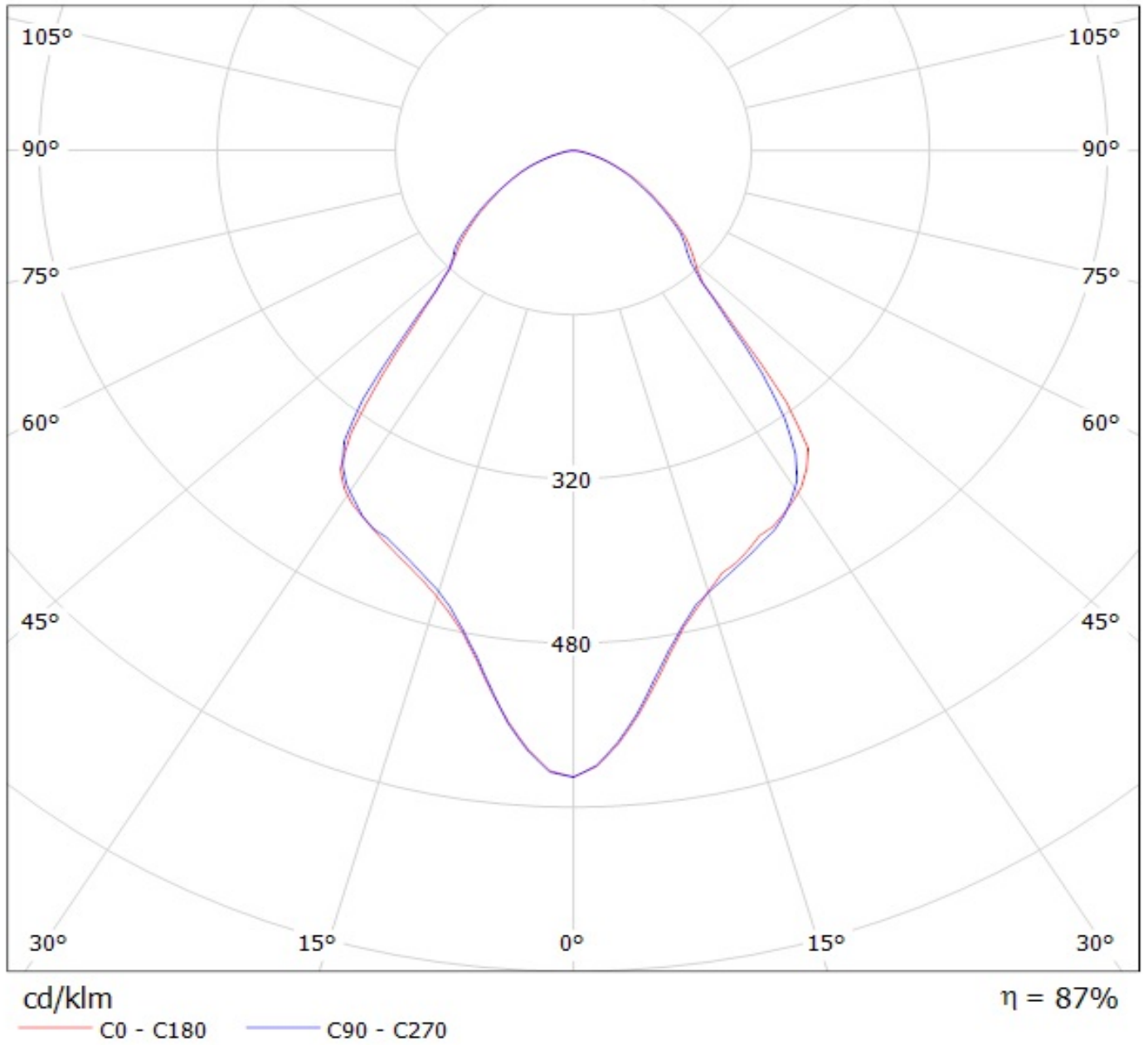

**NOTE: The typical divergence will be changed by different color, chip size and chip position tolerance. The typical total divergence is the full angle measured where the luminous intensity is half of the peak value.**

### **GENERAL INFORMATION**

- Product series especially designed & optimized for series of LEDs.
- Special care taken to make light distribution as uniform as possible.

Note! Due to use of high power COB's with this product, special attention to proper thermal design is highly recommended. LEDiL has no liability for direct, indirect or consecutive damages arising from the LEDiL products being used outside of the recommended temperature range.