

Features

- Micropower consumption for battery powered applications
- Omnipolar, output switches with absolute value of North or South pole from magnet
- Operation down to 1.6V
- High sensitivity for direct reed switch replacement applications

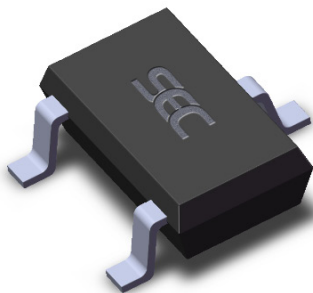

3 pin SOT23 (suffix SO)

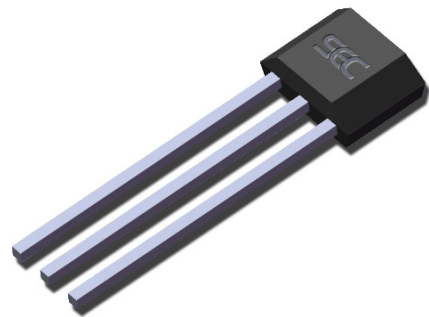

3 pin SIP (suffix UA)

General Description

The SS3413-A Omnipolar Hall effect sensor IC is fabricated from mixed signal CMOS technology. It incorporates advanced chopper-stabilization techniques to provide accurate and stable magnetic switch points.

The circuit design provides an internally controlled clocking mechanism to cycle power to the Hall element and analog signal processing circuits. This serves to place the high current-consuming portions of the circuit into a “Sleep” mode. Periodically the device is “Awakened” by this internal logic and the magnetic flux from the Hall element is evaluated

against the predefined thresholds. If the flux density is above or below the Bop/Brp thresholds then the output transistor is driven to change states accordingly. While in the “Sleep” cycle the output transistor is latched in its previous state. The design has been optimized for service in applications requiring extended operating lifetime in battery powered systems.

The output transistor of the SS3413-A will be latched on (Bop) in the presence of a sufficiently strong South or North magnetic field facing the marked side of the package. The output will be latched off (Brp) in the absence of a magnetic field.

Applications

- Solid state switch
- Handheld Wireless Handset Awake Switch
- Lid close sensor for battery powered devices
- Magnet proximity sensor for reed switch replacement in low duty cycle applications

Typical Application Circuit

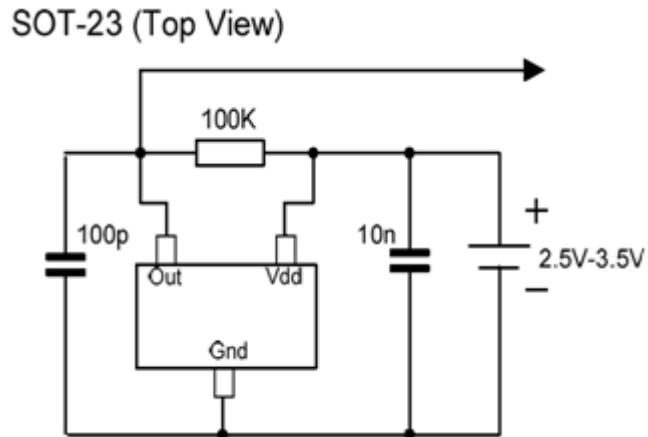

SEC's pole-independent sensing technique allows for operation with either a north pole or south pole magnet orientation, enhancing the manufacturability of the device. The state-of-the-art technology provides the same output polarity for either pole face. It is strongly recommended that an external bypass

capacitor be connected (in close proximity to the Hall sensor) between the supply and ground of the device to reduce both external noise and noise generated by the chopper-stabilization technique. This is especially true due to the relatively high impedance of battery supplies.

Functional Block Diagram

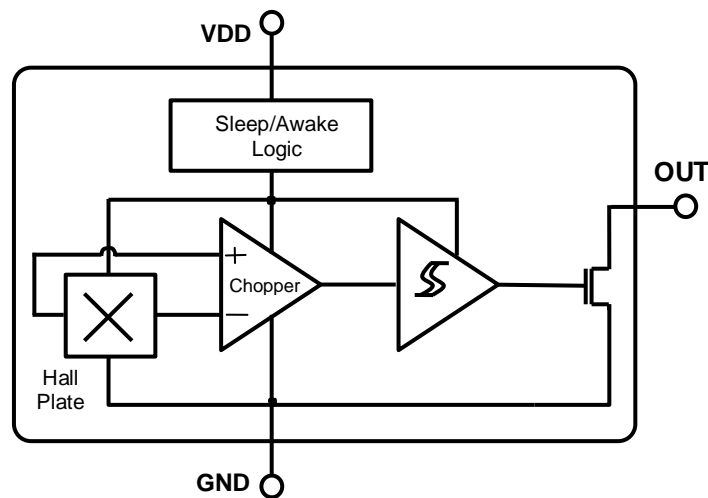

Pin Definitions and Descriptions

SOT Pin №	SIP Pin №	Name	Type	Function
1	1	V _{DD}	Supply	Supply Voltage pin
2	3	OUT	Output	Open Drain Output pin
3	2	GND	Ground	Ground pin

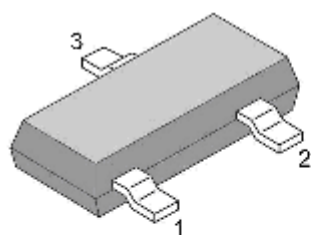
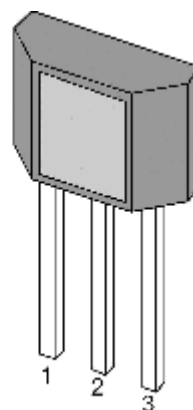
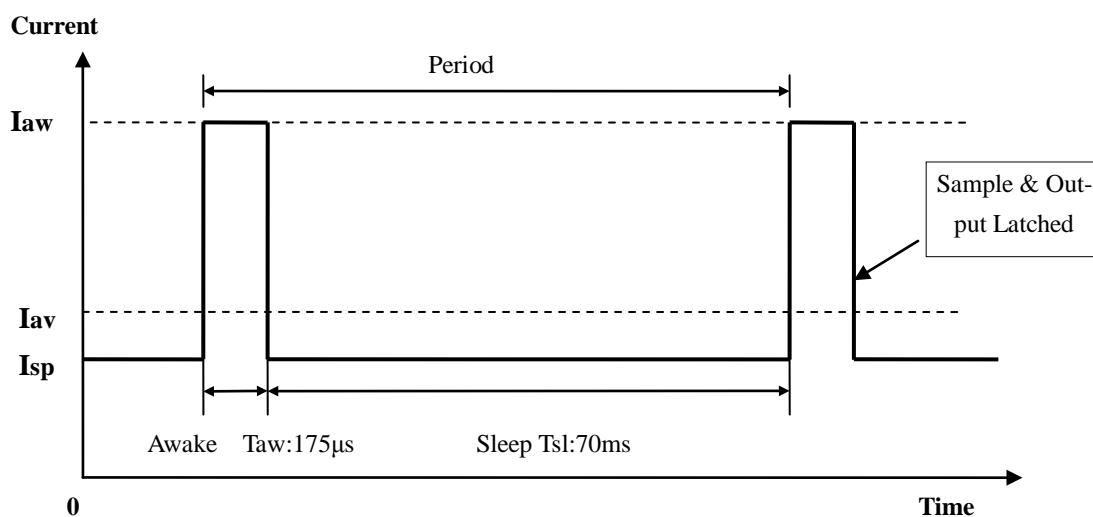
SOT-23

TO-92
Internal Timing Circuit

Absolute Maximum Ratings

Parameter	Symbol	Value	Units
Supply Voltage(operating)	V_{DD}	6	V
Supply Current	I_{DD}	5	mA
Output Voltage	V_{OUT}	6	V
Output Curent	I_{OUT}	5	mA
Operating Temperature Range	T_A	-40 to 85	°C
Storage Temperature Rang	T_S	-50 to 150	°C
ESD Sensitivity	-	4000	V

Exceeding the absolute maximum ratings may cause permanent damage. Exposure to absolute-maximum rated conditions for extended periods may affect device reliability.

DC Electrical Characteristics

DC Operating Parameters: $T_A = 25^\circ\text{C}$, $V_{DD}=2.75\text{V}$.

Parameter	Symbol	Test Conditions	Min	Typ	Max	Units
Operating voltage	V_{DD}	Operating	1.6	2.4	3.5	V
Supply current	I_{DD}	Average		5		μA
Output Current	I_{OUT}				1.0	mA
Saturation Voltage	V_{SAT}	$I_{OUT}=1\text{mA}$			0.4	V
Awake mode time	T_{AW}	Operating		175		μS
Sleep mode time	T_{SL}	Operating			70	mS

Magnetic Characteristics

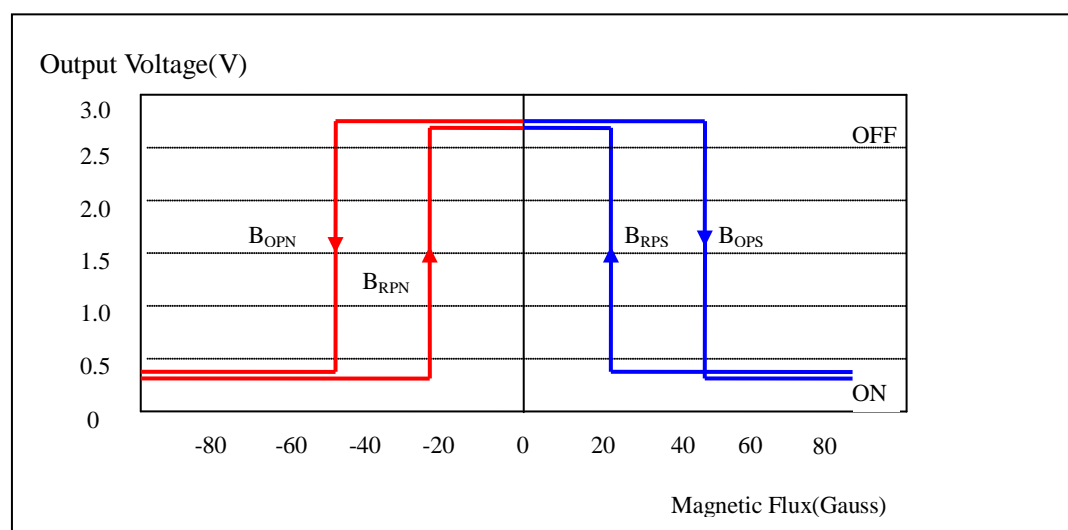

Operating Parameters: $T_A = 25^\circ\text{C}$, $V_{DD}=2.75\text{V}_{DC}$.

PARAMETER	Symbol	Min	Type	Max	Units
Operating Point	B_{op}	-	+/-35	+/-60	Gs
Release Point	B_{rp}	+/-5	+/-21	-	Gs
Hysteresis	B_{hys}	-	14	-	Gs

ESD Protection

Human Body Model (HBM) tests according to: Mil. Std. 883F method 3015.7

Parameter	Symbol	Limit Values		Unit	Notes
		Min	Max		
ESD Voltage	V_{ESD}		± 4	kV	

Performance Characteristics

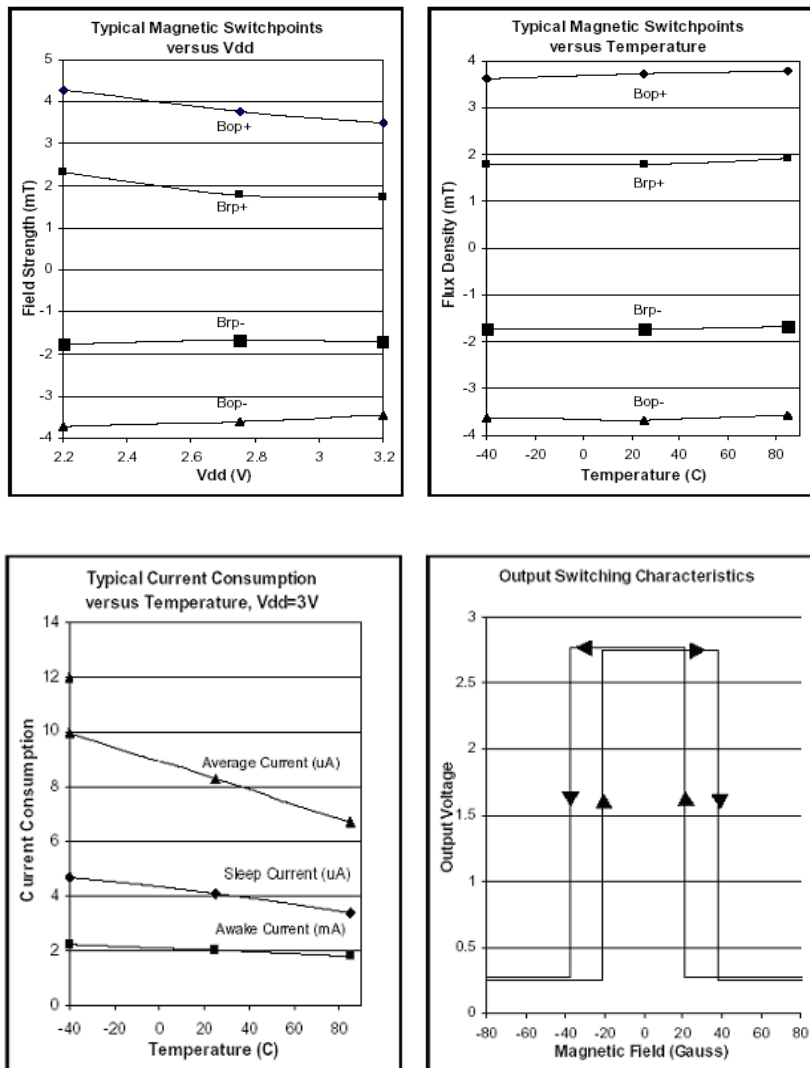

Unique Features

CMOS Hall IC Technology

The chopper stabilized amplifier uses switched capacitor techniques to eliminate the amplifier offset voltage, which, in bipolar devices, is a major source of temperature sensitive drift. CMOS makes this advanced technique possible. The CMOS chip is also much smaller than a bipolar chip, allowing very sophisticated circuitry to be placed in less space. The small chip size also contributes to lower physical stress and less power consumption.

Installation Comments

Consider temperature coefficients of Hall IC and magnetics , as well as air gap and life time variations. Observe temperature limits during wave soldering. Typical IR solder-reflow profile:

- No Rapid Heating and Cooling.
- Recommended Preheating for max. 2minutes at 150°C
- Recommended Reflowing for max. 5seconds at 240°C

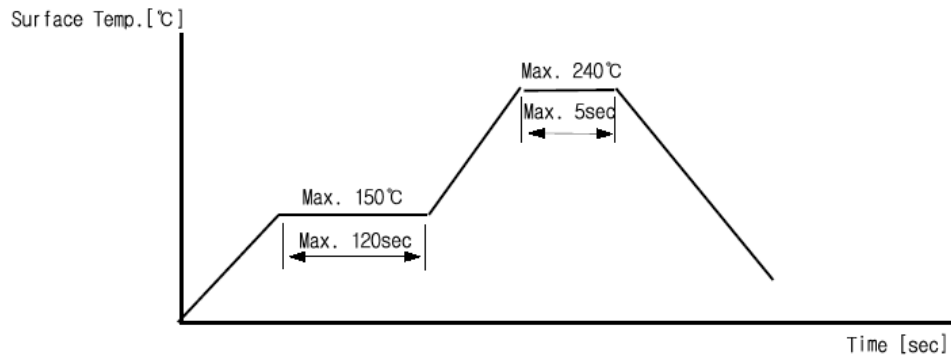

ESD Precautions

Electronic semiconductor products are sensitive to Electro Static Discharge (ESD). Always observe Electro Static Discharge control procedures whenever handling semiconductor products.

Package Information

Package SO, 3-Pin SOT-23:

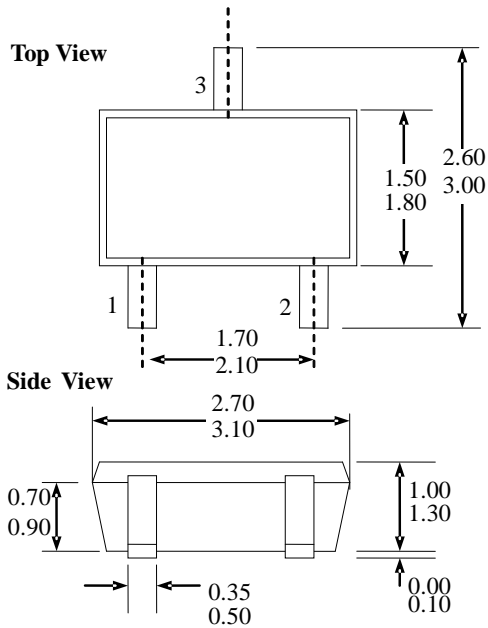

Notes

- PINOUT:** Pin 1 V_{DD}
Pin 2 Output
Pin 3 GND
- All dimensions are in millimeters;

End View

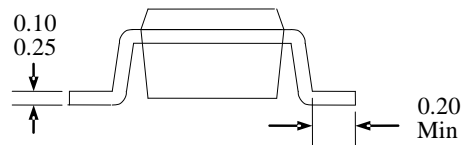

SOT-23 Package Hall Location

Bottom View of SOT-23 Package

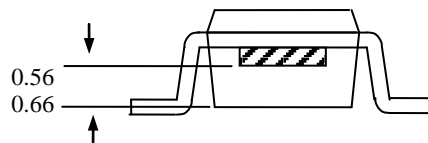
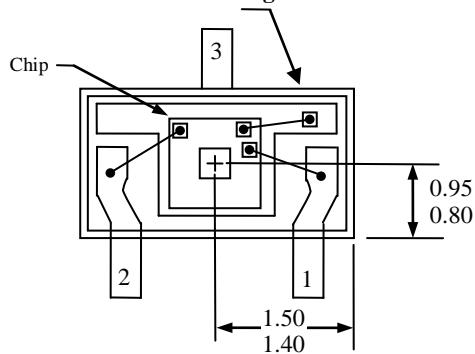

Package ST, 3-Pin TSOT-23:

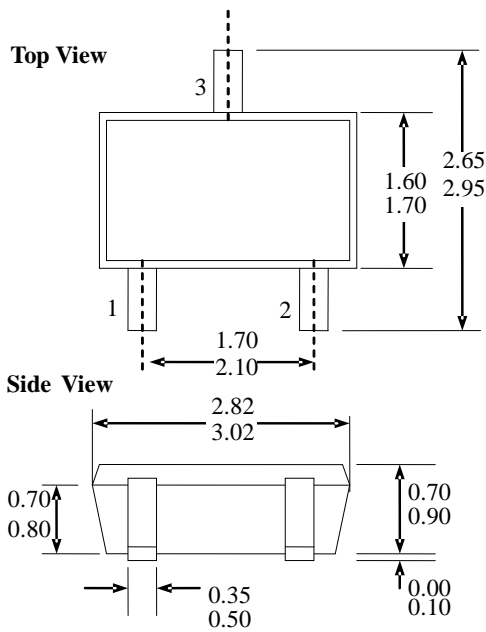

Notes

- PINOUT:** Pin 1 V_{DD}
Pin 2 Output
Pin 3 GND
- All dimensions are in millimeters;

End View

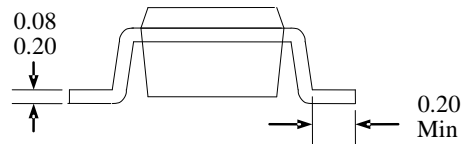

TSOT-23 Package Hall Location

Bottom View of TSOT-23 Package

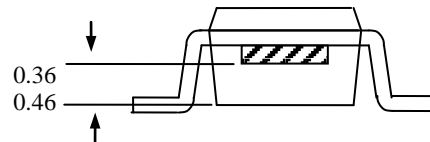
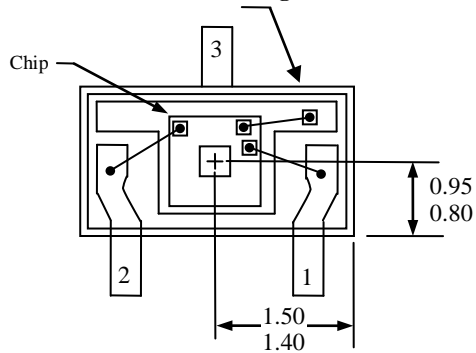

Package UA, 3-Pin SIP:

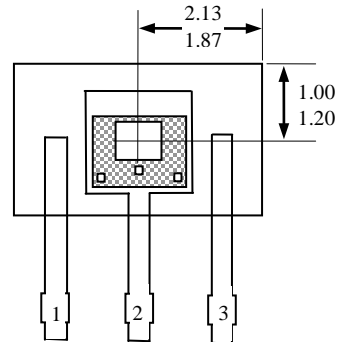
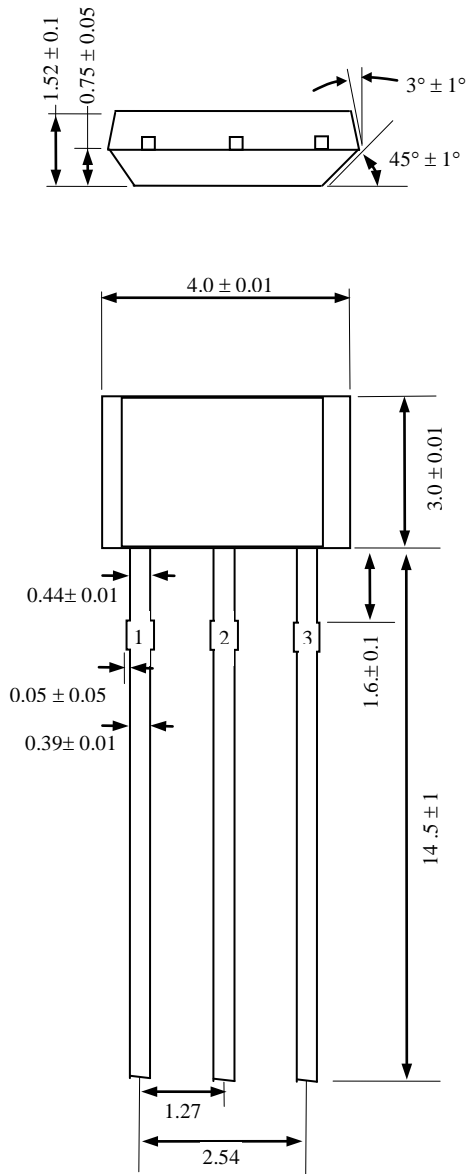

Sensor Location

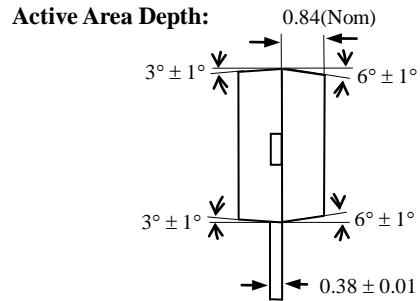

Notes:

- 1). Controlling dimension : mm ;
- 2). Leads must be free of flash and plating voids ;
- 3). Do not bend leads within 1 mm of lead to package interface ;
- 4). PINOUT: Pin 1 V_{DD}
Pin 2 GND
Pin 3 Output

Ordering Information

Part No.	Pb-free	Temperature Code	Package Code	Packing
SS3413-AESOT	YES	-40°C to 85°C	SOT-23	7-in. reel, 3000 pieces/ reel
SS3413-AESTT	YES	-40°C to 85°C	TSOT-23	7-in. reel, 3000 pieces/ reel
SS3413-AEUA	YES	-40°C to 85°C	TO-92	Bulk, 1000 pieces/ bag
SS3413-AKSOT	YES	-40°C to 125°C	SOT-23	7-in. reel, 3000 pieces/ reel
SS3413-AKSTT	YES	-40°C to 125°C	TSOT-23	7-in. reel, 3000 pieces/ reel
SS3413-AKUA	YES	-40°C to 125°C	TO-92	Bulk, 1000 pieces/ bag
SS3413-ALSOT	YES	-40°C to 150°C	SOT-23	7-in. reel, 3000 pieces/ reel
SS3413-ALSTT	YES	-40°C to 150°C	TSOT-23	7-in. reel, 3000 pieces/ reel
SS3413-ALUA	YES	-40°C to 150°C	TO-92	Bulk, 1000 pieces/ bag