

DESCRIPTION

The EV6902DS-00A is an evaluation board for the MP6902DS. It is configured to provide synchronous rectification solution for Flyback/LLC topology.

MP6902DS features a synchronous gate output which enables high efficiency rectification by relating the schottky rectifier with a low Ron MOSFET.

ELECTRICAL SPECIFICATIONS

Parameter	Symbol	Value	Units
Supply Voltage	V _{DD}	8–24	V

FEATURES

- Works with both Standard and Logic Level FETS
- Compatible with Energy Star, 1W Standby Requirements
- V_{DD} Range From 8V to 24V
- Fast Turn-off Total Delay of 20ns
- Max 400kHz Switching Frequency
- <300μA Quiescent Current at Light Load Mode
- Supports CCM, DCM and Quasi-Resonant Topologies
- Supports High-side and Low-side Rectification
- Power Savings of Up to 1.5W in a Typical Notebook Adapter

APPLICATIONS

- Industrial Power Systems
- Distributed Power Systems
- Battery Powered Systems
- Flyback/LLC Converters

"MPS" and "The Future of Analog IC Technology" are Registered Trademarks of Monolithic Power Systems, Inc.

EV6902DS-00A EVALUATION BOARD



(L x W x H) 1.14" x 1.14" x 0.6"
2.9cm x 2.9cm x 1.4cm

Board Number	MPS IC Number
EV6902DS-00A	MP6902DS

EVALUATION BOARD SCHEMATIC

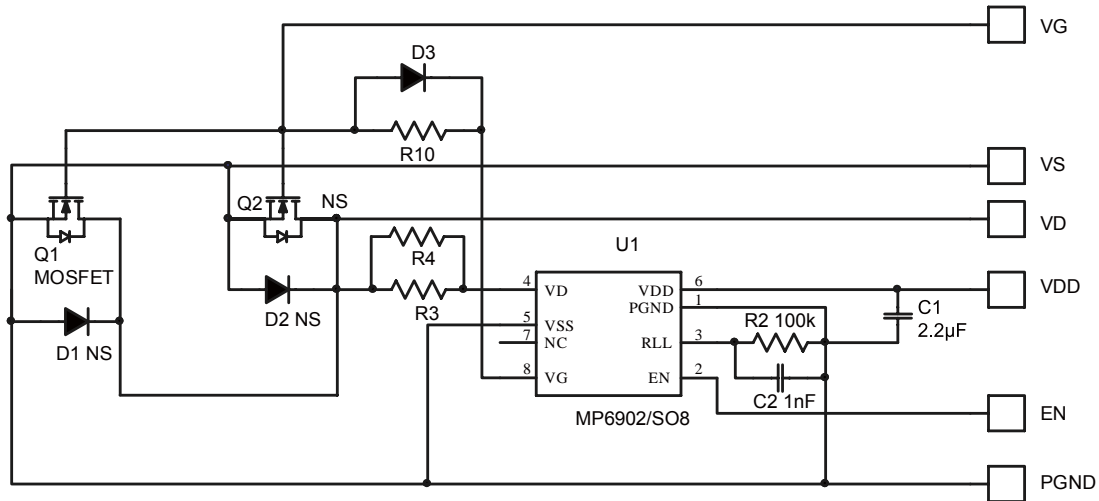

EV6902DS-00A BILL OF MATERIALS

Qty	RefDes	Value	Description	Package	Manufacturer	Manufacturer P/N
1	C1	2.2 μ F	Ceramic Cap., 25V, X7R	0805	muRata	GRM21BR71E225KA73L
1	C2	1nF	Ceramic Cap., 50V, X7R	0603	TDK	C1608X7R1H102K
1	R1	0	Film Res., 5%	0603	Yageo	RC0603JR-070RL
1	R2	100k	Film Res., 1%	0603	Yageo	RC0603FR-07100KL
1	R3	1k	Film Res., 1%	0603	Royalohm	0603F1001T5E
0	R4	NS				
1	Q1	MOSFET	N-CH 100V 8.8m Ω N-CH 100V 8m Ω	TO220-AB TO220	Vishay APEC	SUP90N10-8M8P AP85T10GP
0	Q2	NS		PowerPAK-SO8		
0	D1	NS		SMB		
0	D2	NS		TO220		
1	D3	DIODES	75V/0.15A	SOD323		IN4148WS-7-F
1	U1	MP6902DS	MP6902DS	SO-8	MPS	MP6902DS

PRINTED CIRCUIT BOARD LAYOUT

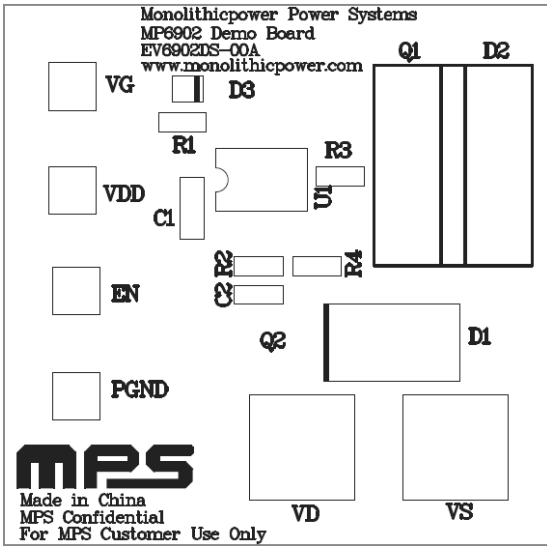

Figure 1—Top Silk Layer

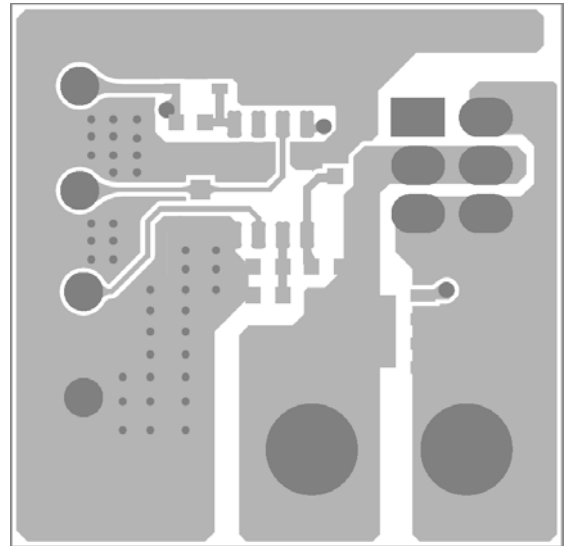

Figure 2—Top Layer

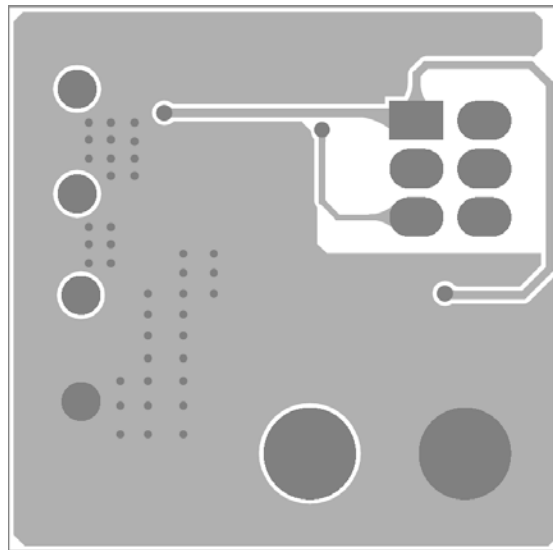

Figure 3—Bottom Layer

QUICK START GUIDE

1. Connect the positive and negative terminals of the power supply to the VDD and PGND pins, respectively.
2. Preset the power supply output 8V~24V, then turn off the power supply.
3. Connect the Drain and Source and Gate terminals of the synchronous power MOSFET to the VD and VS and VG pins, respectively (There is already a 100V power MOSFET Q1 connected on the board, if the customer do not want to use this MOS as synchronous MOSFET, you can remove this Q1 and use your own MOSFET instead).
4. Turn the power supply on. The IC will automatically startup and drive the synchronous MOSFET Q1 to work as an ideal diode.

NOTICE: The information in this document is subject to change without notice. Users should warrant and guarantee that third party Intellectual Property rights are not infringed upon when integrating MPS products into any application. MPS will not assume any legal responsibility for any said applications.