



The Future of Analog IC Technology®

EV2005DD-01B

500mA Low-Current LDO Linear Regulator EV Board

DESCRIPTION

The EV2005DD-01B evaluation board demonstrates the performance of MP2005, a monolithic low-current, low-dropout LDO linear regulator. It operates from a 2.5V to 5V input bias voltage and regulates the output voltage from as low as 0.5V.

The EVB can supply up to 500mA of load current with a typical dropout voltage of 75mV. It requires a bias supply (2.5V to 5.5V) separate from V_{IN} to run the internal reference and LDO drive circuitry. The output current comes directly from the input voltage supply for high efficiency regulation. The 0.5V internal reference voltage allows the output to be programmed to a range of 0.5V to 5V.

The EV2005DD-01B provides thermal overload and current limit protection, stability with ultra low ESR ceramic capacitors, and fast transient response. The MP2005 is available in a 8-pin QFN (2mm x 3mm) package and is also available in fixed output voltage versions.

ELECTRICAL SPECIFICATIONS

Parameter	Symbol	Value	Units
Input Voltage	V_{IN}	1.0 – 5	V
Blas Voltage	V_B	5	V
Output Current	I_{OUT}	0.5	A
Output Voltage	V_{OUT}	1.8	V

FEATURES

- Wide 1.0V to 5V Input Voltage Range
- Stable with Very Small Ceramic Capacitors
- 75mV Dropout at 500mA Output
- 2% Accurate Output Voltage
- Adjustable Output Range from 0.5V to 5V
- Low Noise: $80\mu V_{RMS}$ (10Hz to 100kHz)
- High PSRR: 40dB at 1MHz
- Stable With Low-ESR Output Capacitors
- Low $100\mu A$ Ground Current
- Internal Thermal Protection
- Current Limit Protection
- Fully Assembled and Tested

APPLICATIONS

- Low Current Regulators
- Low Power Handheld Devices
- Battery Powered Systems
- Cellular Phones
- Portable Electronic Equipment
- Post Regulation for Switching Power Supplies
- Power Supplies

All MPS parts are lead-free, halogen free, and adhere to the RoHS directive. For MPS green status, please visit MPS website under Quality Assurance. "MPS" and "The Future of Analog IC Technology" are Registered Trademarks of Monolithic Power Systems, Inc.

EV2005DD-01B EVALUATION BOARD



L x W x H) 2.9" x 2.9" x 0.5"
(7.5cm x 7.5cm x 1.2cm)

Board Number	MPS IC Number
EV2005DD-01B	MP2005

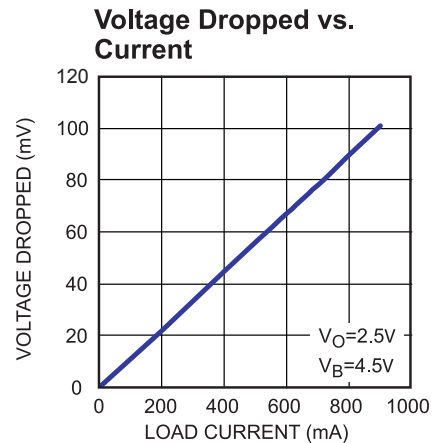

EVALUATION BOARD SCHEMATIC

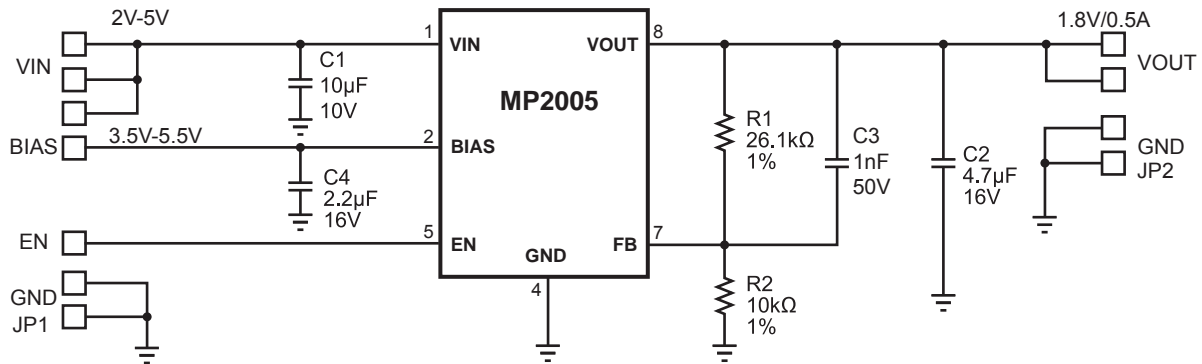

EV2005DD-01B BILL OF MATERIALS

Qty	Ref	Value	Description	Package	Manufacturer	Manufacturer P/N
1	C1	10µF	Ceramic Cap., X7R, 10V	1206	TDK	C3216X7R1C106K
1	C4	2.2µF	Ceramic Cap., X7R, 16V	0805	TDK	C2012X7R1C225K
1	C2	4.7µF	Ceramic Cap., X7R, 16V	1206	TDK	C3216X7R1C475K
1	C3	1nF	Ceramic Cap X7R, 50V	0603	muRata	GRM188R71H102KA01D
1	R1	26.1kΩ	Film Res., 1%	603	Panasonic	ERJ-3EKF2612V
1	R2	10kΩ	Film Res., 1%	603	Panasonic	ERJ-3EKF1002V
1	JP		10-Pin Header, 0.1"		Sullins	PTC08SAAN
1	JP		5-Pin Header, 0.1"		Sullins	PTC08SAAN
1	U1		Linear Regulator	QFN-8	MPS	MP2005DD

PRINTED CIRCUIT BOARD LAYOUT

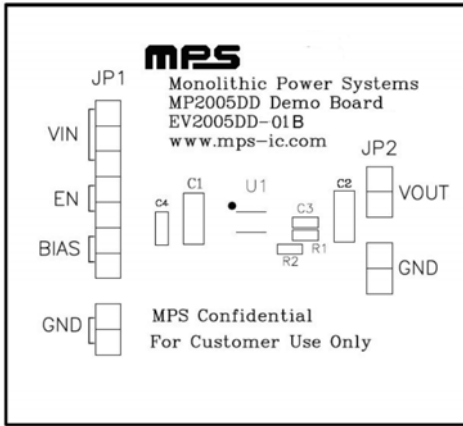

Figure 1—Top Silk Layer

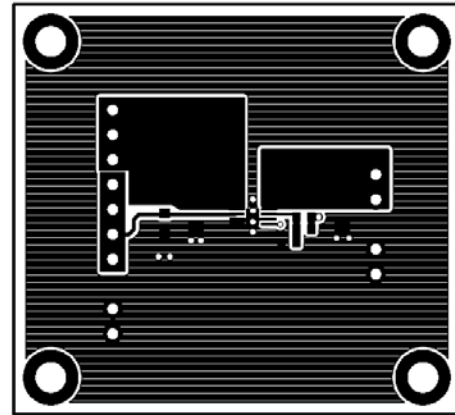

Figure 2—Top Layer

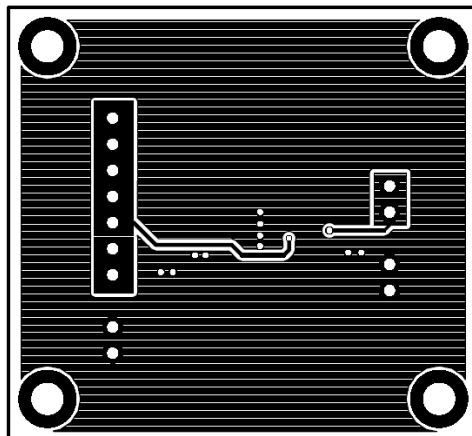

Figure 3—Bottom Layer

QUICK START GUIDE

The output voltage of this board is set to 1.8V. The EN pin is connected to BIAS with a jumper for automatic startup. You can connect EN to GND to disable the MP2005

1. Attach the positive and negative ends of the load to the VOUT and GND pins, respectively.
2. Attach the input voltage ($2V \leq V_{IN} \leq 5V$) and input ground to the VIN and GND pins, respectively.
3. Attach the BIAS voltage ($3.5V \leq V_{BIAS} \leq 5.5V$) and BIAS ground to the BIAS and GND pins, respectively.
4. The VIN voltage and BIAS voltage can be set up to same voltage but it has to meet :

$$V_{IN}=V_{BIAS}>(1.8V + V_{OUT}) \text{ and } V_{BIAS}>2.7V$$

5. The default resistor values on the board are $R1=26.1k\Omega$ and $R2=10k\Omega$. Changing these resistor values will change the output voltage. Use the following equation to determine resistor values for different output voltages:

$$V_{OUT} = 0.5V \times \left(1 + \frac{R1}{R2}\right)$$

NOTICE: The information in this document is subject to change without notice. Users should warrant and guarantee that third party Intellectual Property rights are not infringed upon when integrating MPS products into any application. MPS will not assume any legal responsibility for any said applications.