

DESCRIPTIONS

The EC49021 is designed for USB dedicated charging port (DCP) controller. The EC49021 can automatically detect and provide the correct signal on the D+ and D- data lines to the USB devices. The internal dedicated charging schemes can change the charging mode for the different USB device.

- BC1.2 DCP that short the D+ line to the D- line
- Apple divider DCP that apply specified voltage on the D+ and D- lines
- Samsung specification that apply specified voltage on the D+ and D- lines

The EC49021 set the USB interface data D+ and D- to the required condition then the handheld charging device will start to charge current as much as possible from the power source .

FEATURE

- Operating range: 4.5V to 5.5V
- Automatically switch data lines D+ and D- connections for the attached USB device
- Supports Samsung device charging mode
- Supports BC1.2 charging specification mode
- Supports selectable Apple 1A ,2A and 2.4A charging mode
- Supports most of mainstream USB device fast charging
- RoHS compliant and lead-free package
- SOT23-5 package

APPLICATION

- AC-DC wall adapter with USB port
- Vehicle USB power charger
- Other USB charger
- Power bank USB charger



ORDERING INFORMATION

EC49021NN XX X
| └─┬─> R : Tape & Reel
B2 : SOT23-5

Part Number	Package	Marking	Marking Information
EC49021NNB2R	SOT23-5L	49021 LLLLL	1. LLLLL : Lot No.

PIN INFORMATION

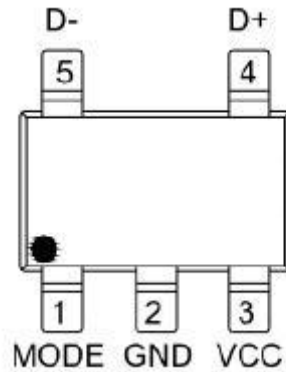

PIN DESCRIPTION

Pin	Symbol	Type	Function
1	MODE	Input	Internal default pull high Mode selection: 1A, 2A and 2.4A
2	GND	Ground	Ground
3	VCC	Power	Power
4	D+	Bi-direction	USB positive data line
5	D-	Bi-direction	USB negative data line

REFERENCE APPLICATION CIRCUIT

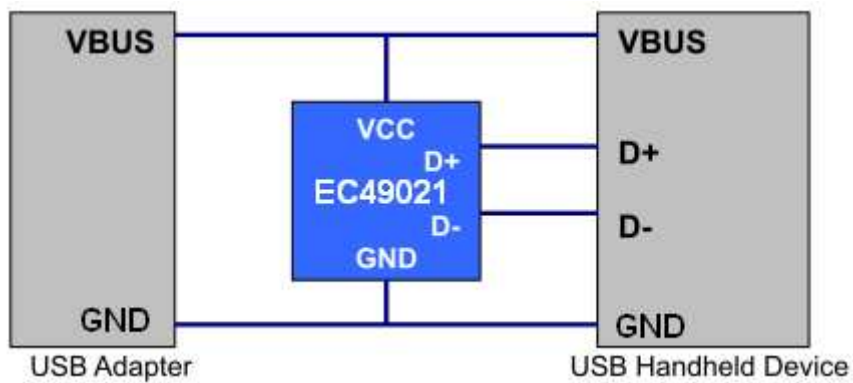

ABSOLUTE MAXIMUM RATINGS

PARAMETER		MIN	MAX	UNITS
Supply Voltage	VCC	-0.3	7	V
Input / Output Voltage	MODE, D+, D-	-0.3	7	V
Operating Temperature Range	TO	-20	+85	°C
Storage Temperature Range	TS	-65	150	°C
ESD Protection Rating	Human Body Model (HBM) ^{*NOTE1}	±8 (Class-3B)		KV
	Machine Model (MM) ^{*NOTE2}	±200 (Class-M4)		V

Note1: Testing Facility:

- Testing Ambient Condition [Temperature: 25±5 °C] [Humidity:55±10%]
- Reference Documents [MIL-STD-883H/Method 3015.8]
- Human Body Model Rating:
 - Class 0: 0V ~ 249V
 - Class 1A: 250V ~ 499V
 - Class 1B: 500V ~ 999V
 - Class 1C: 1000V ~ 1999V
 - Class 2: 2000V ~ 3999V
 - Class 3A: 4000V ~ 7999V
 - Class 3B: 8000V ~

Note2: Testing Facility:

- Testing Ambient Condition [Temperature: 25±5 °C] [Humidity:55±10%]
- Reference Documents [AHSI/ESD S5.2-2009]
- Machine Model Rating
 - Class M1: 0V ~ 99V
 - Class M2: 100V ~ 199V
 - Class M3: 200V ~ 399V
 - Class M4: 400V ~

CAUTION



This integrated circuit has been designed carefully in the ESD protection ability. Failure to observe proper handling and installation procedures may cause damage. Recommend that all integrated circuits should be handled with appropriate precautions.

ELECTRICAL CHARACTERISTICS (For VCC=5V and Tj=25 oC)

PARAMETER	CONDITIONS	MIN	TYP	MAX	UNITS
VCC					
Operating range, Vcc	-	4.5	-	5.5	V
Operating current, Icc	Vcc=5V	-	500	-	uA
MODE, D+, D-					
D+ output impedance	Vcc=5V	35	-	65	KΩ
D- output impedance	Vcc=5V	35	-	65	KΩ
MODE, D+, D-	-	0	-	Vcc,	V

FUNCTION DESCRIPTION

1. The EC49021 is an USB dedicated charging port (DCP) controller. The built-in auto-detect function can monitors the voltage of D+ and D- data lines. To provide the correct voltage level on the D+ and D- data lines automatically, the compliant USB devices can be charged with the charging current as much as possible. That can reduce the charging time when use the EC49021 as the controller in the USB charge feature kit.

2. MODE truth table

MODE	Function
External pull-high with R1(1KΩ)	Apple 2A mode
External pull-down with R2(1KΩ)	Apple 1A mode
External pull-down with R2(2MΩ)	Apple 2.4A mode

Reference Application Circuit

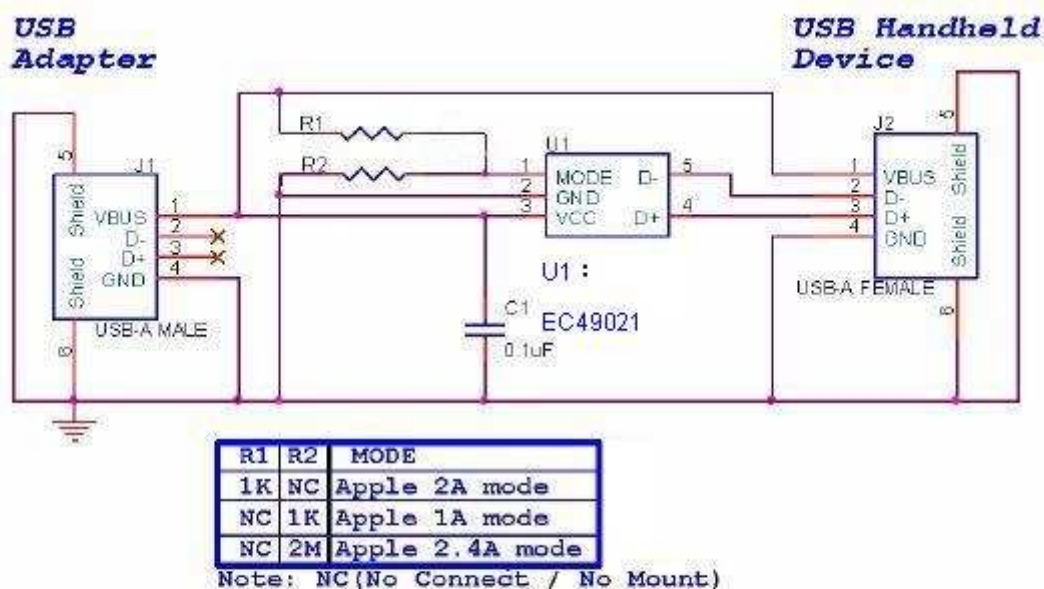

CAUTION:

When select the charge mode, please make sure the current ability of power source that can provide the desired continue current. Any maximum continue charging current must not exceed the limited of the maximum current rating of the power source, like wall adapter, vehicle USB charger, and other USB charger.

2. The EC49021 only control the voltage of D+ / D- lines on the USB port to support the auto-detect charging procedure and does not control the USB power (VBUS) operation. The remaining battery capacity in the compliant USB devices may affect the charging current. If the remaining battery capacity is low, the charging current may be high. Conversely the charging current may be low when the remaining battery capacity is high.

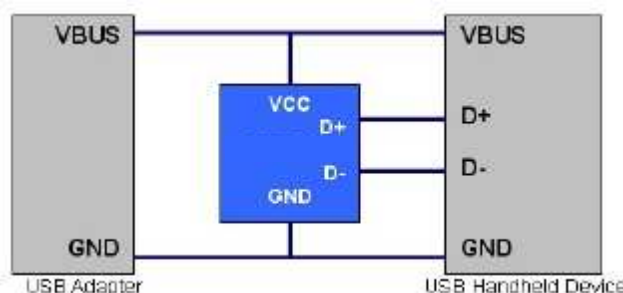

4. The EC49021 support most of the common protocols:

- USB Battery Charging Specification, Revision 1.2(BC 1.2)
- China Telecommunications Industry Standard YD/T 1591-2009
- Specified Divider Mode

5. There are three types of charging ports defined to provide different current to the USB device.

- Standard downstream port(SDP)
- Charging downstream port(CDP)
- Dedicated charging port(DCP)

The BC1.2 specification defines the charging USB port that provides power for the portable device.

6. Dedicated Charging Port (DCP) The DCP is a downstream port on the device which generally allows portable devices with fast charge at their maximum rated current. A USB charger with DCP can be a wall adapter or vehicle power adapter. The electrical characteristics in the data D+ and D- data lines can identify the charging mode.

7. Short the D+ line to the D- line

The USB BC1.2 Specification and the China Telecommunications Industry Standard YD/T 1501-2009 define the D+ and D- should be shorted. This is shown as below

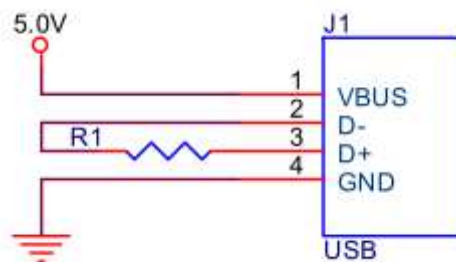

8. Divider Mode

There are some different charging schemes for the DCP mode. All of them have different voltage levels on the D+ line and D- line. This is shown as below

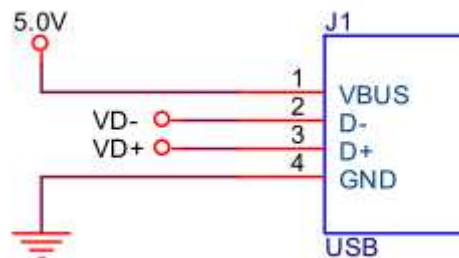

The EC49021 can detect the D+ line and D- line voltages automatically and provide the correct signals on the D+ and D- pins for the different USB portable device to fast charge.

IMPORTANT NOTICE

The products are not intended for use in life support appliances, devices, or systems. Use in such applications are expressly prohibited.

PACKAGE DIMENSIONS

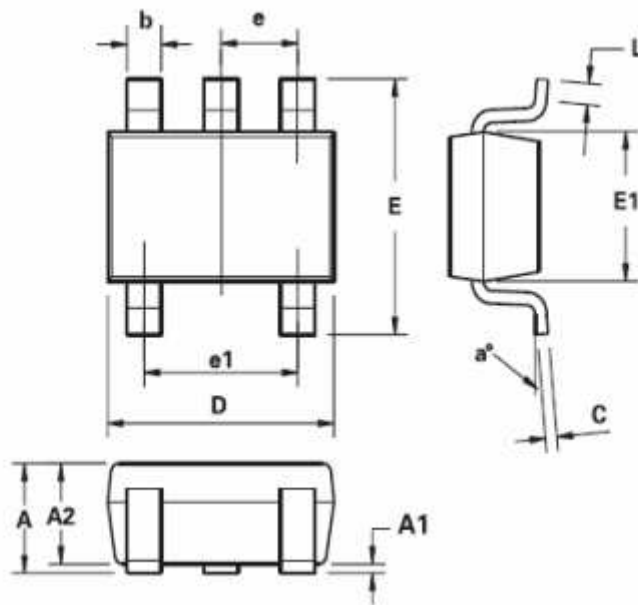

DIM	Millimeters	
	Min.	Max.
A	0.90	1.45
A1	0.00	0.15
A2	0.90	1.30
b	0.20	0.50
C	0.09	0.26
D	2.70	3.10
E	2.20	3.20
E1	1.30	1.80
e	0.95 REF	
e1	1.90 REF	
L	0.10	0.60
a°	0°	30°