

## SAW BANDPASS FILTER

**ACT PART NO.: ACTF9357\_2140MHz\_DCC6C\_V1.0**

<b>Product Type:</b>		<b>Customer:</b>
SAW Filter		
<b>Part NO.:</b>	ACTF9357_2140MHz_DCC6C_V1.0	<b>Customer Part NO.:</b>
		<b>Issued Date:</b>

<b>PREPARED BY</b>	<b>CHECKED BY</b>	<b>APPROVED BY</b>

In line with our ongoing policy of product evolution and improvement, the above specification may subject to change without notice

**ISO9001 Registered**

For quotations or further information please contact us at:

3 The Business Centre, Molly Millars Lane, Wokingham, Berkshire, RG41 2EY, UK

<http://www.actcrystals.com>

## Features

- Low-loss RF filter
- High Rejection
- Single Ended Operation at 50Ω without matching
- Ceramic Package for **Surface Mounted Technology (SMT)**
- Lead-free Production and **RoHS** Compliance

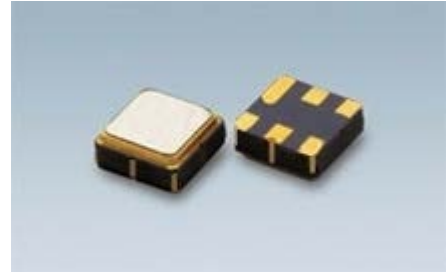

## Package Dimensions

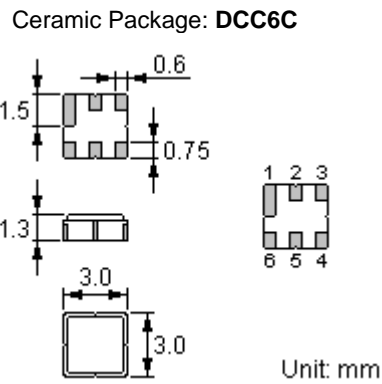

## Pin Configuration

2	Input
5	Output
1, 3, 4, 6	Case Ground
1, 3, 4, 6	To Be Grounded

## Marking

### Top View, Laser Marking

**ACTF**  
**9357**

"**ACT**": Manufacturer's mark

"**F**": SAW filter

"**9357**": Part number

" . ": Terminal 1

" \* ": Lot number (The code shown below varies in a 4-year cycle)

Code	1	2	3	4	5	6	7	8	9	10	11	12
2011	a	b	c	d	e	f	g	h	i	j	k	m
2012	n	p	q	r	s	t	u	v	w	x	y	z
2013	A	B	C	D	E	F	G	H	J	K	L	M
2014	N	P	Q	R	S	T	U	V	W	X	Y	Z

## Maximum Ratings

Rating		Value	Unit
Input Power Level	$P$	24.5 dBm CW, $T_a=85^{\circ}\text{C}$ , life time>2 hurs	
		24 dBm CW, $T_a=95^{\circ}\text{C}$ , life time>2 hurs	
		18 dBm CW, $T_a=85^{\circ}\text{C}$ , life time>1000 hurs	
		17 dBm CW, $T_a=95^{\circ}\text{C}$ , life time>1000 hurs	
		13 dBm CW, $T_a=85^{\circ}\text{C}$ , life time>100,000 hurs	
		12 dBm CW, $T_a=95^{\circ}\text{C}$ , life time>100,000hurs	
DC Voltage	$V_{DC}$	0	V
ESD Voltage (HB)	$V_{ESD}$	150	V
Operating Temperature Range	$T_A$	-40 ~ +95	$^{\circ}\text{C}$
Storage Temperature Range	$T_{stg}$	-40 ~ +95	$^{\circ}\text{C}$

## Electrical Characteristics

Item		Minimum	Typical	Maximum	Unit
Center Frequency	$f_c$	-	2140	-	MHz
Maximum Insertion Loss in 2110 MHz–2170 MHz	$IL$	-	3.0	3.5	dB
Amplitude Variation in 2110 MHz–2170 MHz			1.0	1.5	dB
Absolute Attenuation	$\alpha$				
50.0 ... 1400.0 MHz		22	27	-	dB
1400.0 ... 1910.0 MHz		25	28	-	dB
1910.0 ... 1980.0 MHz		30	38	-	dB
2300.0 ... 3700.0 MHz		25	30	--	dB
3700.0 ... 5300.0 MHz		20	25	--	dB
5300.0 ... 5700.0 MHz		15	18	--	dB
Input VSWR in 2110 MHz–2170 MHz		-	1.5:1	2.0:1	
Output VSWR in 2110 MHz–2170 MHz		-	1.5:1	2.0:1	
Group delay ripple 2110 MHz–2170 MHz			10	30	ns
Source / Load Impedance (single ended)			50		$\Omega$

 RoHS Compliant

 Electrostatic Sensitive Device

# Typical Frequency Response

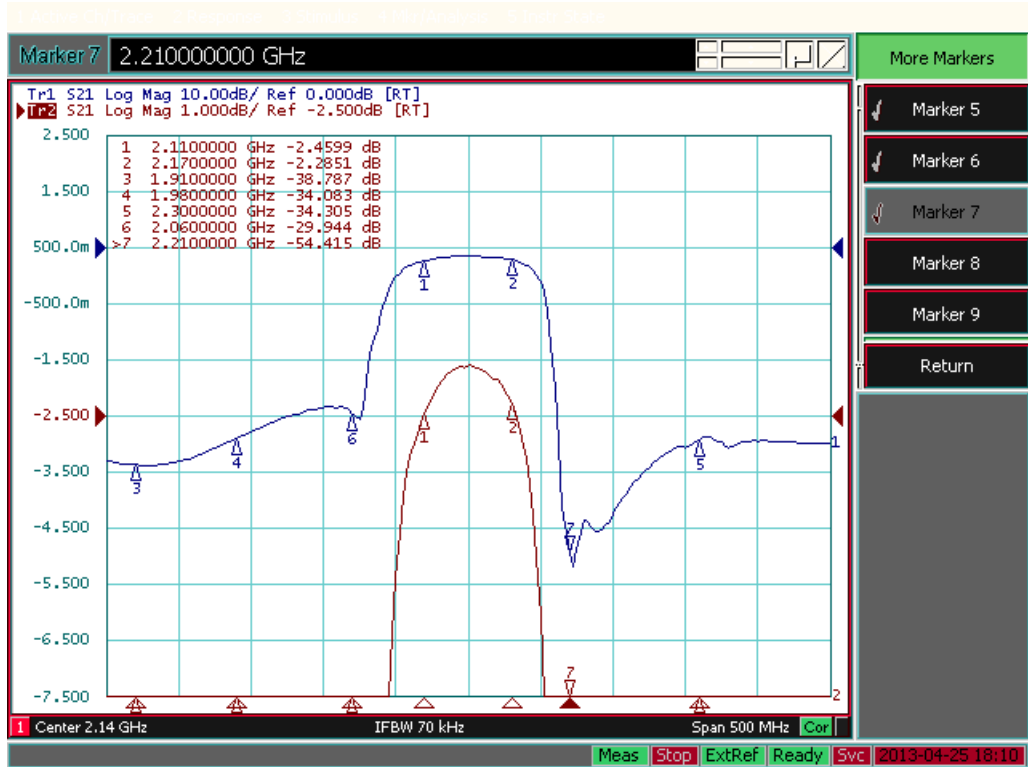

# S11 S22



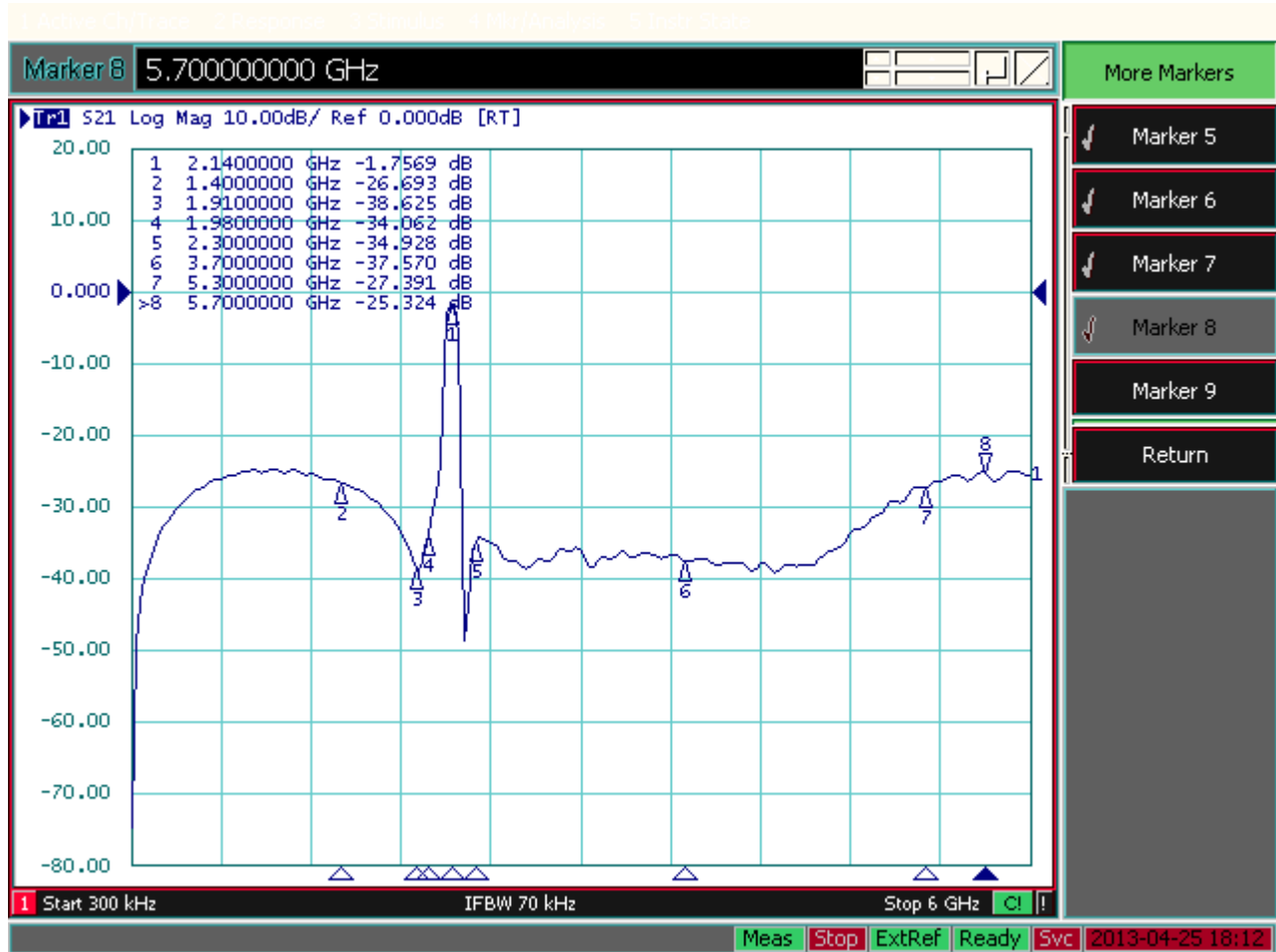

### Stability Characteristics

	Test item	Condition of test
1	Mechanical shock	(a) Drops: 3 times on concrete floor (b) Height: 1.0 m
2	Vibration resistance	(a) Frequency of vibration: 10~55Hz      (b) Amplitude: 1.5 mm (c) Directions: X,Y and Z                      (d) Duration: 2 hours
3	Moisture resistance	(a) Condition: 40°C, 90~95% R.H.      (b) Duration: 96 hours (c) Wait 4 hours before measurement
4	Climatic sequence	(a) +70°C for 16 hours                      (b) +55°C for 24 hours, 90~95% R.H. (c) -25°C for 2 hours                      (d) +40°C for 24 hours, 90~95% R.H. (e) Wait 4 hours before measurement
5	High temperature exposure	(a) Temperature: 70°C                      (b) Duration: 250 hours (c) Wait 4 hours before measurement
6	Thermal impact	(a) +70°C for 30 minutes ⇒ -25°C for 30 minutes repeated 3 times (b) Wait 4 hours before measurement

**Requirements:** The SAW filter shall remain within the electrical specifications after tests.

## Remarks

- SAW devices should not be used in any type of fluid such as water, oil, organic solvent, etc.
- Be certain not to apply voltage exceeding the rated voltage of components.
- Do not operate outside the recommended operating temperature range of components.
- Sudden change of temperature shall be avoided, deterioration of the characteristics can occur.
- Be careful of soldering temperature and duration of components when soldering.
- Do not place soldering iron on the body of components.
- Be careful not to subject the terminals or leads of components to excessive force.
- SAW devices are electrostatic sensitive. Please avoid static voltage during operation and storage.
- Ultrasonic cleaning shall be avoided. Ultrasonic vibration may cause destruction of components.

## Test Circuit

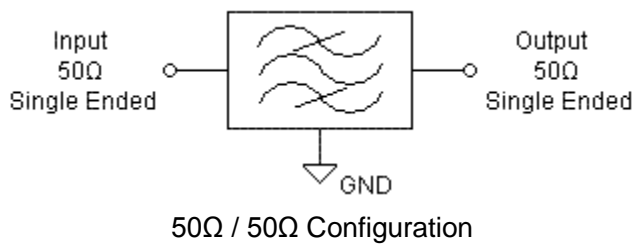

## Recommended Land Pattern

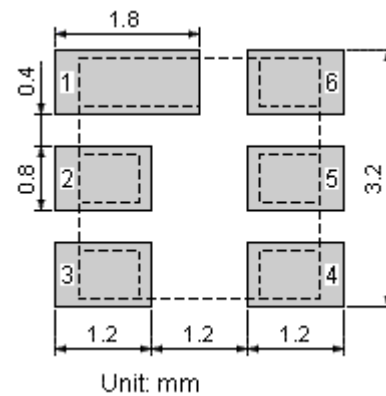

## Packing Information

### Carrier Tape

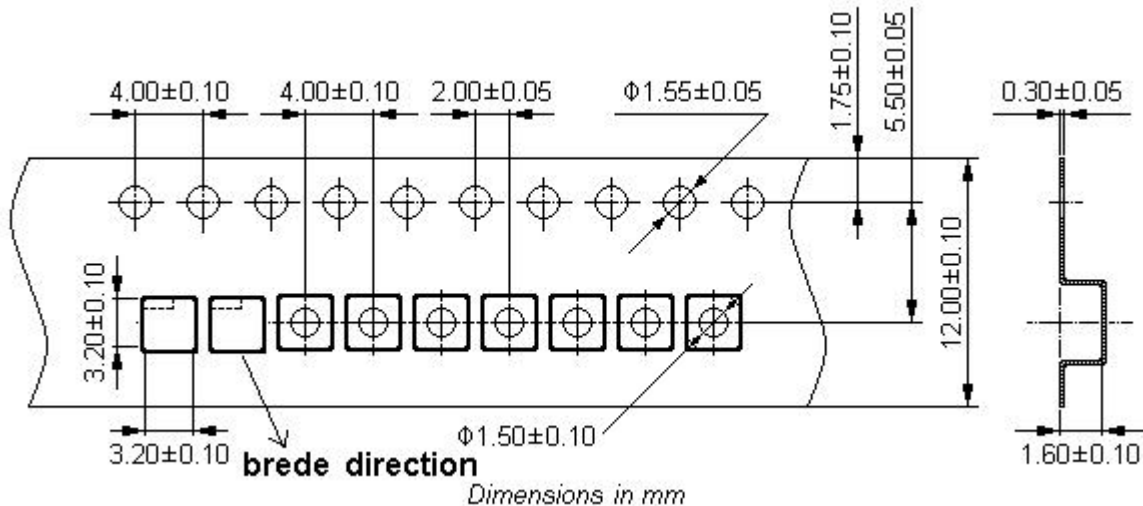

### Reel Dimensions

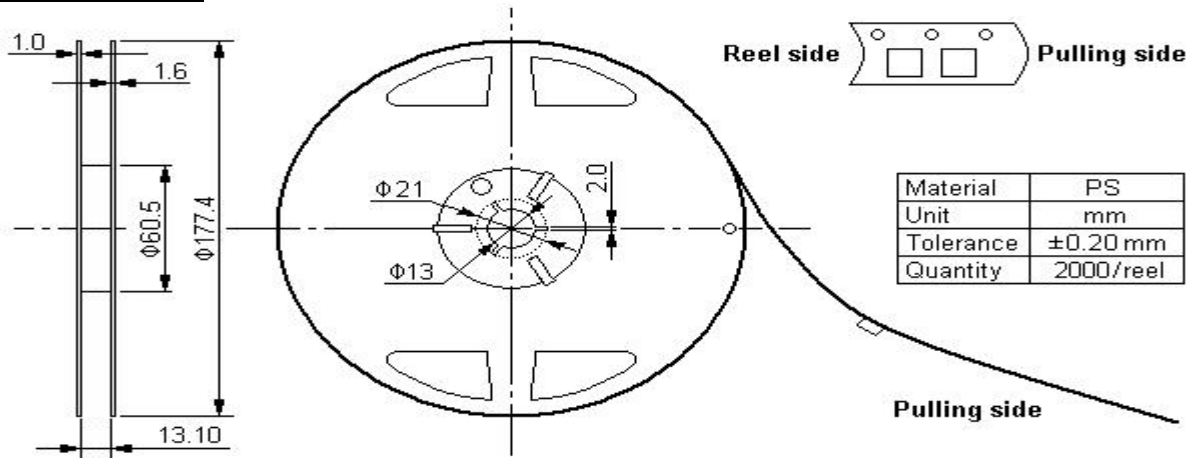

### Outer Packing

Type	Quantity	Dimension	Description	Weight
Carton Box I	10000	190x190x95	anti-static plastic bag & carton box 1 reel / bag	0.85
Carton Box II	20000	190x190x190	5 bags / box (10000 pcs) 10 bags / box (20000 pcs)	1.70

Unit: mm

Unit: kg

### Recommended Soldering Profile

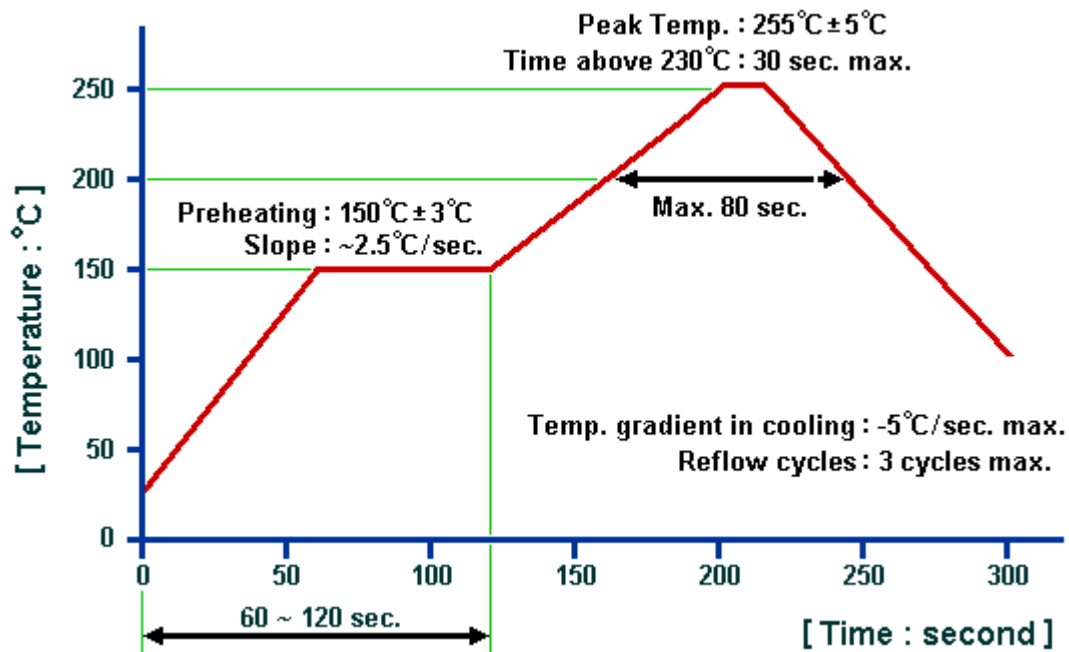

### © ACT 2013 All Rights Reserved.

1. The specifications of this device are subject to change or obsolescence without notice.
2. Typically, equipment utilizing this device requires emissions testing and government approval, which is the responsibility of the equipment manufacturer.
3. Our liability is only assumed for the Surface Acoustic Wave (SAW) component(s) per se, not for applications, processes and circuits implemented within components or assemblies.