

DATA SHEET

SKY65131: WLAN Power Amplifier Module

Applications

- IEEE802.11 b/g WLAN
- ISM band transmitters
- WCS fixed wireless
- Wireless access nodes

Features

- Single 3.3 V supply
- Linear output power of +28 dBm for IEEE802.11b mask
- Linear output power of +26 dBm for IEEE802.11g mask
- High PAE of 38 percent
- Output power detector: 20 dB dynamic range
- Superior gain flatness
- Internal RF match and bias circuits
- Small MCM (16-pin, 4 x 4 mm), Pb-free SMT package (MSL3, 250 °C per JEDEC J-STD-020)
- PA shutdown control

NEW



Skyworks offers lead (Pb)-free “environmentally friendly” packaging that is RoHS compliant (European Parliament for the Restriction of Hazardous Substances).

Description

The Skyworks SKY65131 is a Microwave Monolithic Integrated Circuit (MMIC) Power Amplifier (PA) with superior output power, linearity, and efficiency. These features make the SKY65131 ideal for Wireless Local Area Network (WLAN) applications.

The device is fabricated using Skyworks high reliability Indium Gallium Phosphide (InGaP) Heterojunction Bipolar Transistor (HBT) technology. The device is internally matched and mounted in a 4 x 4 mm, Multi-Chip Module (MCM) Surface-Mounted Technology (SMT) package, which allows for a highly manufacturable low cost solution.

The device package and pinout are shown in Figure 1. A block diagram of the SKY65131 is shown in Figure 2.

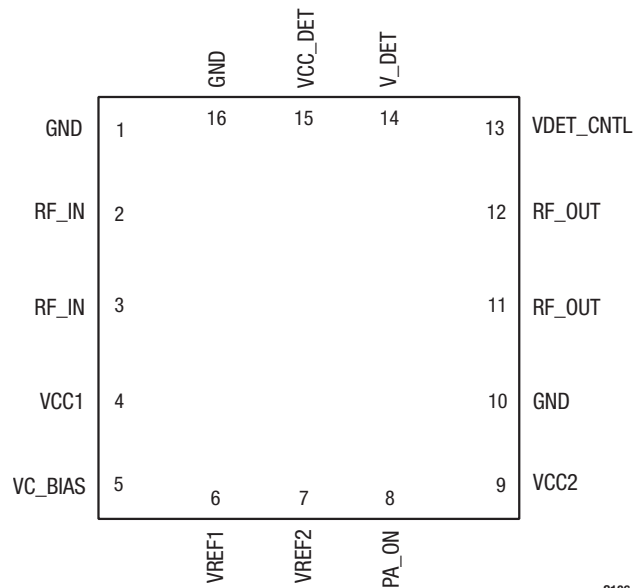

S106

Figure 1. SKY65131 Pinout – 16-Pin MCM (Top View)

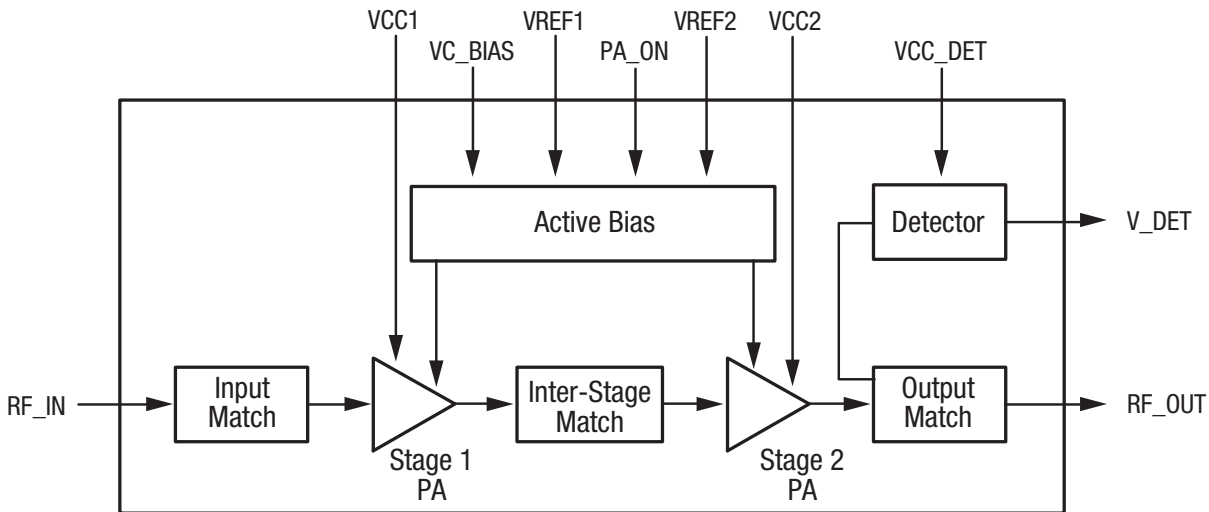

Figure 2. SKY65131 Block Diagram

Technical Description

The SKY65131 PA contains all of the needed RF matching and DC biasing circuits. The device also provides an output power detector voltage and the ability to switch the PA on or off with a simple control signal.

The SKY65131 is a two-stage, HBT InGaP device optimized for high linearity and power efficiency. These features make the device suitable for wideband digital applications, where PA linearity and power consumption are of critical importance (e.g., WLANs).

The device has been characterized with the highest specified data rates for 802.11b (11 Mbps) and 802.11g (54 Mbps). Under these stringent test conditions, the device exhibits excellent spectral purity and power efficiency.

Package and Handling Information

Since the device package is sensitive to moisture absorption, it is baked and vacuum packed before shipping. Instructions on the shipping container label regarding exposure to moisture after the container seal is broken must be followed. Otherwise, problems related to moisture absorption may occur when the part is subjected to high temperature during solder assembly.

The SKY65131 is rated to Moisture Sensitivity Level 3 (MSL3) at 250 °C. It can be used for lead or lead-free soldering. Care must be taken when attaching this product, whether it is done manually or in a production solder reflow environment.

If the part is attached in a reflow oven, the temperature ramp rate should not exceed 5 °C per second. Maximum temperature should not exceed 250 °C. If the part is manually attached,

precaution should be taken to ensure that the part is not subjected to temperatures exceeding 250 °C for more than 10 seconds.

For details on both attachment techniques, precautions, and handling procedures recommended by Skyworks, please refer to Skyworks Application Note, *PCB Design and SMT Assembly/Rework Guidelines for MCM-L Packages*, document number 101752. Additional information on standard SMT reflow profiles can also be found in the JEDEC Standard J-STD-020.

Production quantities of this product are shipped in a standard tape and reel format. For packaging details, refer to the Skyworks Application Note, *Tape and Reel*, document number 101568.

Electrical and Mechanical Specifications

Signal pin assignments and functional pin descriptions are described in Table 1. The absolute maximum ratings of the SKY65131 are provided in Table 2. Electrical specifications are provided in Table 3.

Typical performance characteristics are shown in Figures 3 through 9. A schematic diagram of the SKY65131 Evaluation Board is shown in Figure 10. A PCB layout footprint for the SKY65131 is provided in Figure 14. Package dimensions for the SKY65131 16-pin MCM are shown in Figure 15, and tape and reel dimensions are shown in Figure 16.

Evaluation Board Description

The Skyworks SKY65131 Evaluation Board is used to test the performance of the SKY65131 power amplifier driver. An assembly drawing for the Evaluation Board is shown in Figure 11. The layer detail is provided in Figure 12 and Figure 13 identifies the physical characteristics of each layer.

Electrostatic Discharge (ESD) Sensitivity

The SKY65131 is a static-sensitive electronic device. Do not operate or store near strong electrostatic fields. Take proper ESD precautions.

Table 1. SKY65131 Signal Descriptions

Pin #	Name	Description	Pin #	Name	Description
1	GND	Ground	9	VCC2	Stage 2 collector voltage
2	RF_IN	RF input	10	GND	Ground
3	RF_IN	RF input	11	RF_OUT	RF output
4	VCC1	Stage 1 collector voltage	12	RF_OUT	RF output
5	VC_BIAS	Bias voltage	13	VDET_CNTL	Detector voltage control
6	VREF1	Bias reference voltage 1	14	V_DET	Detector output signal
7	VREF2	Bias reference voltage 2	15	VCC_DET	Detector supply voltage
8	PA_ON	PA on/off control signal	16	GND	Ground

Table 2. SKY65131 Absolute Maximum Ratings

Parameter	Symbol	Minimum	Maximum	Units
RF input power	P_{IN}		4	dBm
Supply voltage	VCC1, VC_BIAS, VREF1, VREF2, VCC2, and VCC_DET		4	V
Supply current ($I_D + I_{BIAS}$)	I_{CC}		500	mA
Power dissipation			2	W
Case operating temperature	T_C	-40	+85	°C
Storage temperature	T_{ST}	-55	+125	°C
Junction temperature	T_J		+150	°C

Note: Exposure to maximum rating conditions for extended periods may reduce device reliability. There is no damage to device with only one parameter set at the limit and all other parameters set at or below their nominal value.

Table 3. SKY65131 Recommended Operating Conditions

Parameter	Symbol	Minimum	Typical	Maximum	Units
RF input power	P_{IN}			-3	dBm
Supply voltage	VCC1, VC_BIAS, VREF1, VREF2, VCC2, and VCC_DET	3.0	3.3	3.6	V
Case operating temperature	T_C	-40		+85	°C
Storage temperature	T_{ST}	-55		+125	°C

Table 4. SKY65131 Electrical Specifications
(VCC = 3.3 V, Tc = +25 °C, Test Frequency = 2.442 GHz Unless Otherwise Noted)

Parameter	Symbol	Test Condition	Min	Typical	Max	Units
Using IEEE802.11b Complimentary Code Keying Input Signal, Data Rate = 11 Mbps						
Supply current	I _{CC}			490		mA
Output power (Note 1)	P _{OUT}			27		dBm
Power added efficiency (Note 2)	PAE			41		%
Ramp-up/ramp-down (Note 3)	T _s			<0.5		μs
Using IEEE802.11g Orthogonal Frequency Division Multiplexing Input Signal, Data Rate = 54 Mbps						
Supply current	I _{CC}			400		mA
Output power (Note 4)	P _{OUT}			26		dBm
Power added efficiency (Note 2)	PAE			33		%
Using Continuous Wave Input Signals						
Small signal gain	G	P _{IN} = -15 dBm		26		dB
Gain flatness over band		From 2.4 GHz to 2.5 GHz		±1.0		dB
Gain flatness over channel (16.25 MHz)		Over any 16.25 MHz within band		±0.2		dB
Output power @ 1 dB compression	P1dB	P _{IN} = 3 dBm		28		dBm
Quiescent Current	I _Q			150		mA
Noise Figure	NF			5		dB
Power added efficiency	PAE	P _{IN} = 3 dBm		38		%
Thermal resistance (junction-to-case)	R _{TH,J-C}			50		C/W
Power Up/Down Control						
Power up	PA_ON/OFF		2.7	3.3		V
Power down	PA_ON/OFF				0.5	V

Note 1: Defined as the maximum power level for which the IEEE802.11b transmit mask requirements are met.

Note 2: Measured at the specified average output RF power and modulation type.

Note 3: Ramp-up and ramp-down times are defined from the 10% to 90% power points.

Note 4: Defined as the maximum power level for which the IEEE802.11g transmit mask requirements are met.

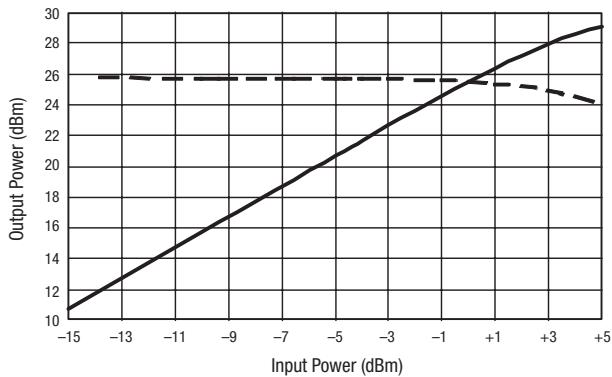

Figure 3. Typical P_{OUT} and Gain vs P_{IN} @ 2.442 GHz

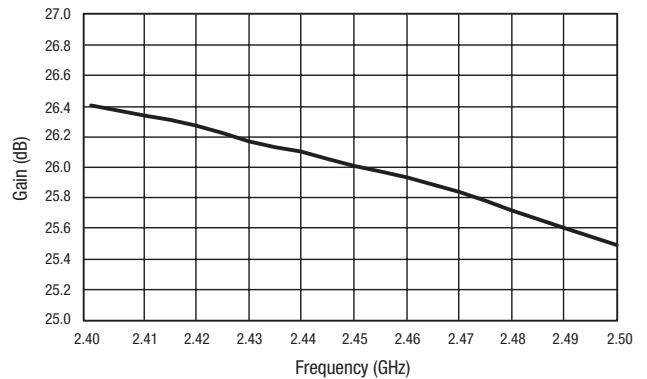

Figure 4. Typical Gain vs Frequency Response

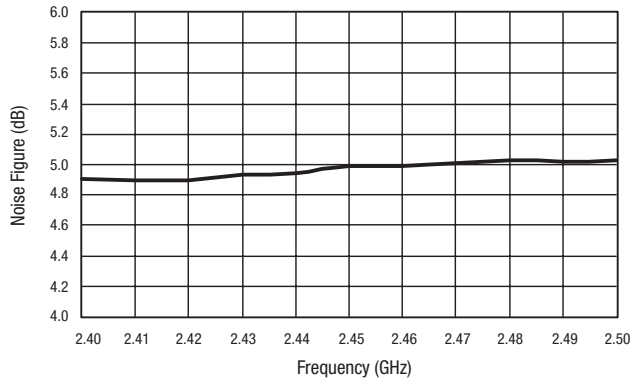

Figure 5. Typical Noise Figure Performance vs Frequency

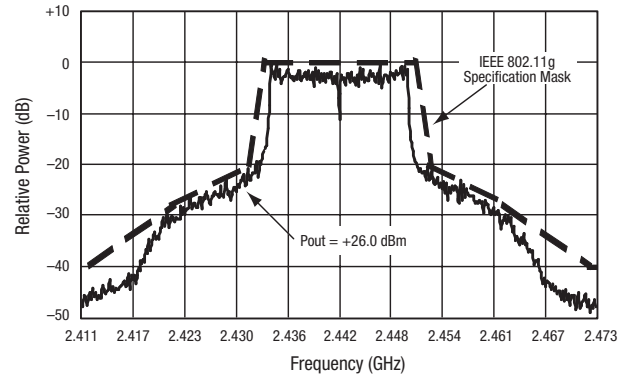

Figure 6. Output Spectrum Response for 802.11g (64 Quadrature Amplitude Modulated, 54 Mbps Input Signal)

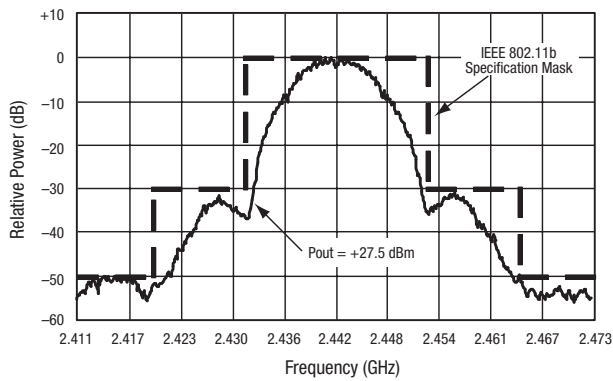

Figure 7. Output Spectrum Response for 802.11b CCK-Coded (11 Mbps Input Signal)

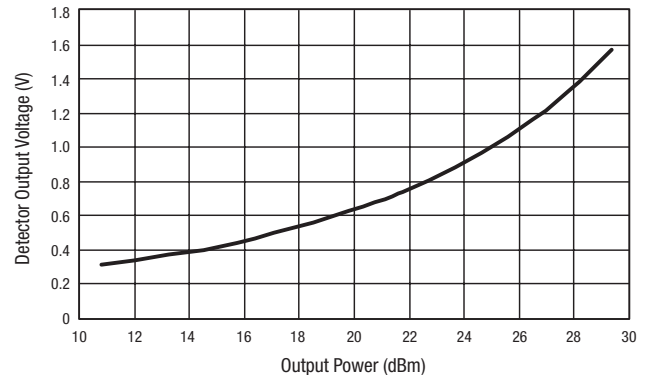

Figure 8. Detector Output Voltage vs RF Output Power

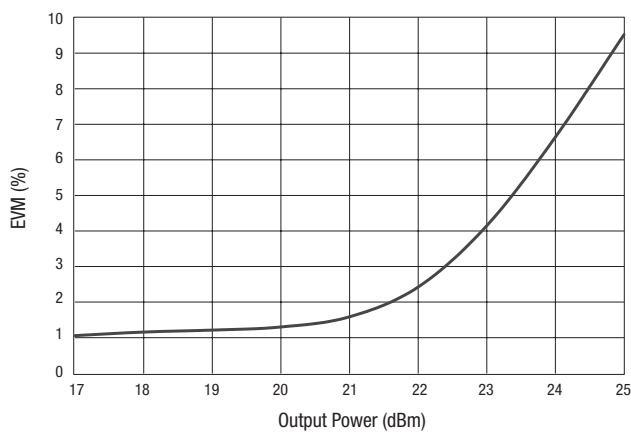
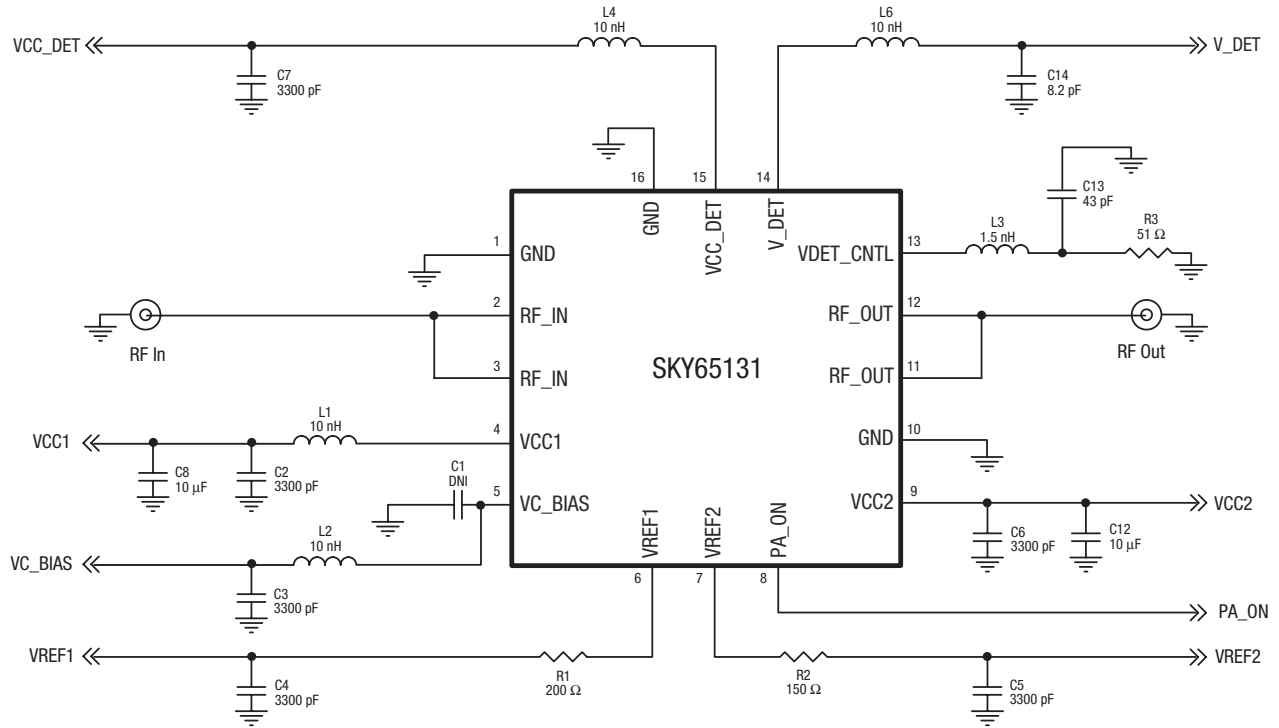

Figure 9. EVM vs Pout for 802.11g (64 Quadrature Amplitude Modulated, 54 Mbps Input Signal)



Note: Evaluation Board material: four-layer Rogers 4003-12, $\epsilon_r = 3.38$

S324

Figure 10. SKY65131 Evaluation Board Schematic

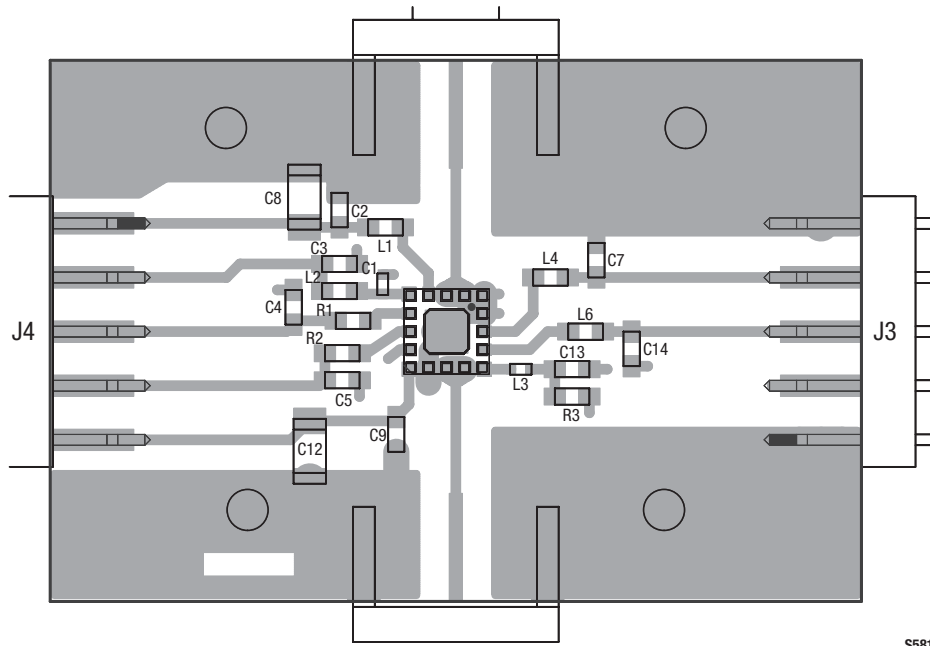

S581

Figure 11. Evaluation Board Assembly Drawing

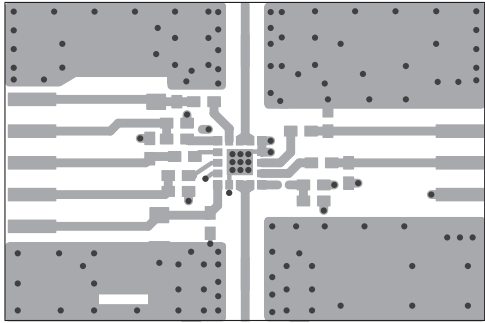

Layer 1: Top Metal

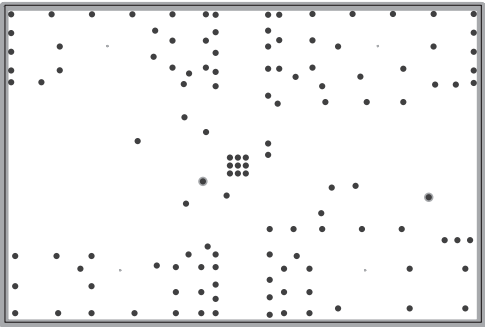

Layer 2: Ground

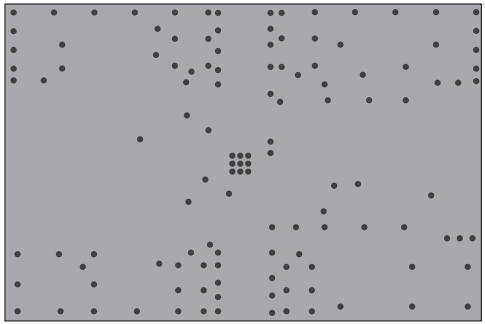

Layer 3: Inner Traces

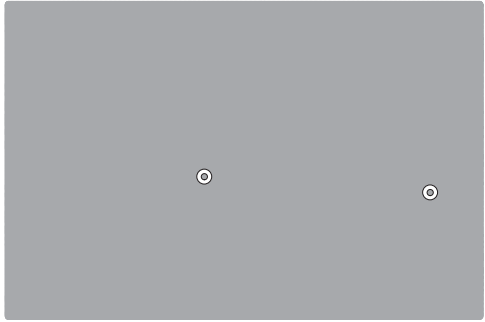

Layer 4: Ground

S580

Figure 12. Evaluation Board Layer Detail

Cross Section	Name	Thickness (mils)	Material	ϵ_r
	L1	1.4	Cu, 1 oz.	-
	Lam1	12	Rogers 4003-12	3.38
	L2_GND	1.4	Cu, 1 oz.	-
	Lam2	4	FR4-4	4.35
	L3_GND	1.4	Cu, 1 oz.	-
	Lam3	12	FR4-12	4.35
	L4	1.4	Cu, 1 oz.	-

S573

Figure 13. Layer Detail Physical Characteristics

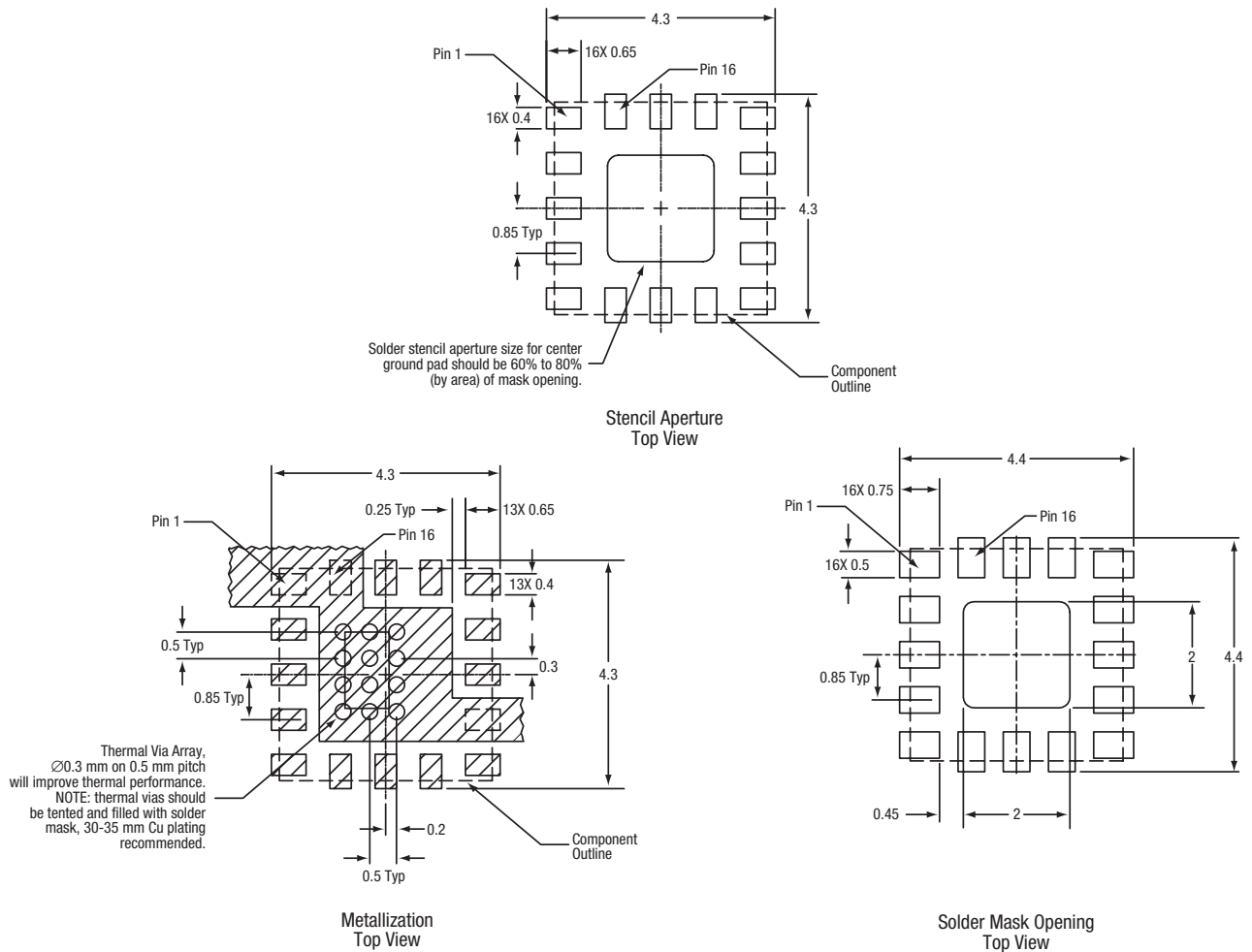
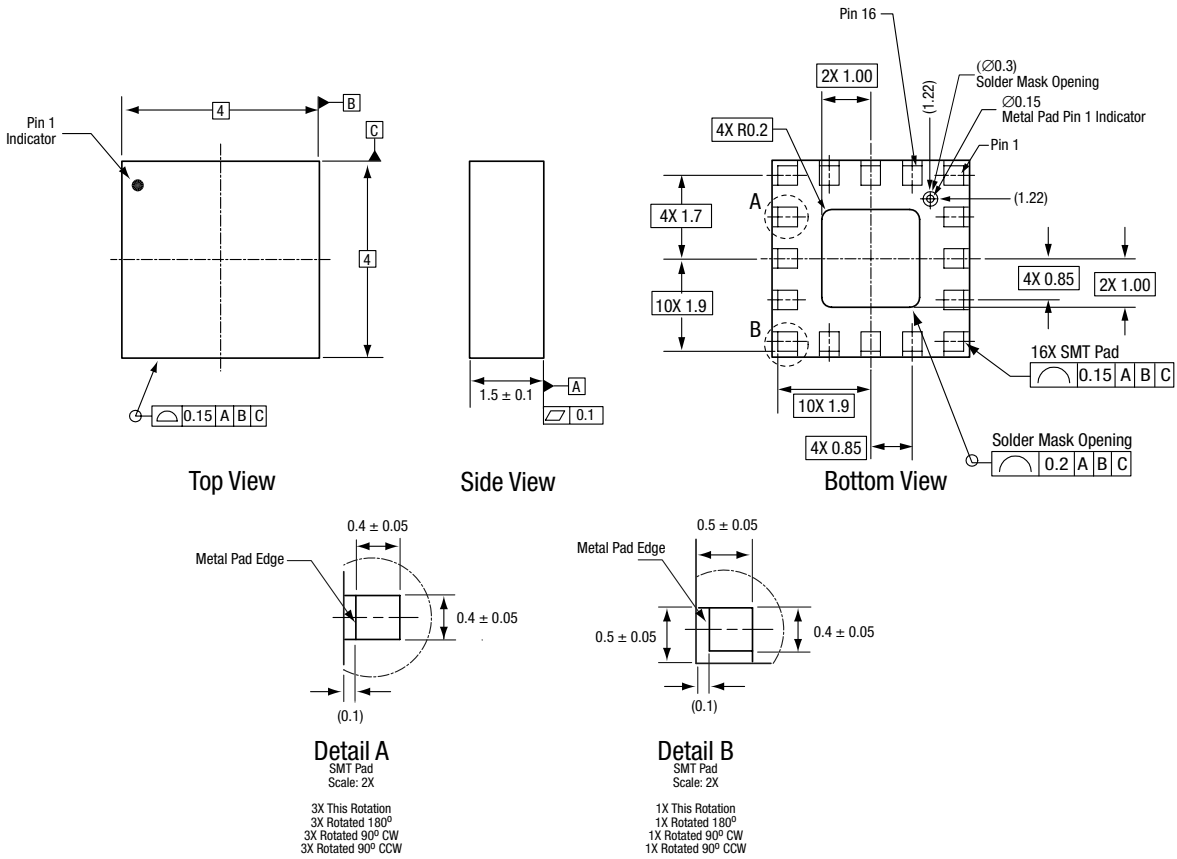

Figure 14. PCB Layout Footprint for the SKY65131 4 x 4 mm MCM



All measurements are in millimeters

Dimensioning and tolerancing according to ASME Y14.5M-1994

S108

Figure 15. SKY65131 16-Pin MCM Package Dimensions

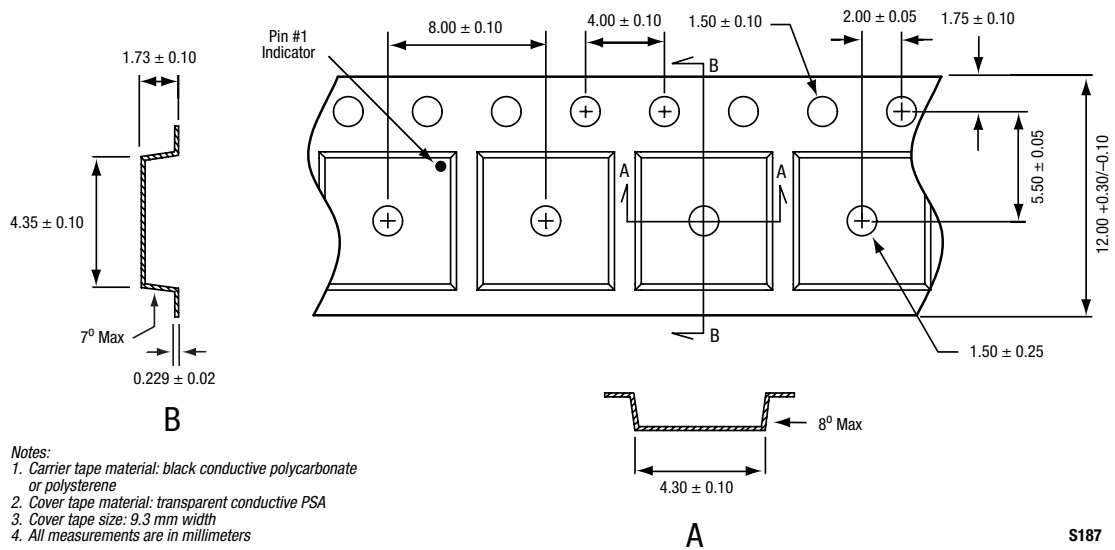

S187

Figure 16. SKY65131 16-Pin MCM Tape and Reel Dimensions

Ordering Information

Model Name	Manufacturing Part Number	Evaluation Kit Part Number
SKY65131 WLAN Power Amplifier Module	SKY65131-21	TW13-D341

Copyright © 2003, 2004, 2005, 2007, 2008 Skyworks Solutions, Inc. All Rights Reserved.

Information in this document is provided in connection with Skyworks Solutions, Inc. ("Skyworks") products or services. These materials, including the information contained herein, are provided by Skyworks as a service to its customers and may be used for informational purposes only by the customer. Skyworks assumes no responsibility for errors or omissions in these materials or the information contained herein. Skyworks may change its documentation, products, services, specifications or product descriptions at any time, without notice. Skyworks makes no commitment to update the materials or information and shall have no responsibility whatsoever for conflicts, incompatibilities, or other difficulties arising from any future changes.

No license, whether express, implied, by estoppel or otherwise, is granted to any intellectual property rights by this document. Skyworks assumes no liability for any materials, products or information provided hereunder, including the sale, distribution, reproduction or use of Skyworks products, information or materials, except as may be provided in Skyworks Terms and Conditions of Sale.

THE MATERIALS, PRODUCTS AND INFORMATION ARE PROVIDED "AS IS" WITHOUT WARRANTY OF ANY KIND, WHETHER EXPRESS, IMPLIED, STATUTORY, OR OTHERWISE, INCLUDING FITNESS FOR A PARTICULAR PURPOSE OR USE, MERCHANTABILITY, PERFORMANCE, QUALITY OR NON-INFRINGEMENT OF ANY INTELLECTUAL PROPERTY RIGHT; ALL SUCH WARRANTIES ARE HEREBY EXPRESSLY DISCLAIMED. SKYWORKS DOES NOT WARRANT THE ACCURACY OR COMPLETENESS OF THE INFORMATION, TEXT, GRAPHICS OR OTHER ITEMS CONTAINED WITHIN THESE MATERIALS. SKYWORKS SHALL NOT BE LIABLE FOR ANY DAMAGES, INCLUDING BUT NOT LIMITED TO ANY SPECIAL, INDIRECT, INCIDENTAL, STATUTORY, OR CONSEQUENTIAL DAMAGES, INCLUDING WITHOUT LIMITATION, LOST REVENUES OR LOST PROFITS THAT MAY RESULT FROM THE USE OF THE MATERIALS OR INFORMATION, WHETHER OR NOT THE RECIPIENT OF MATERIALS HAS BEEN ADVISED OF THE POSSIBILITY OF SUCH DAMAGE.

Skyworks products are not intended for use in medical, lifesaving or life-sustaining applications, or other equipment in which the failure of the Skyworks products could lead to personal injury, death, physical or environmental damage. Skyworks customers using or selling Skyworks products for use in such applications do so at their own risk and agree to fully indemnify Skyworks for any damages resulting from such improper use or sale.

Customers are responsible for their products and applications using Skyworks products, which may deviate from published specifications as a result of design defects, errors, or operation of products outside of published parameters or design specifications. Customers should include design and operating safeguards to minimize these and other risks. Skyworks assumes no liability for applications assistance, customer product design, or damage to any equipment resulting from the use of Skyworks products outside of stated published specifications or parameters.

Skyworks, the Skyworks symbol, and "Breakthrough Simplicity" are trademarks or registered trademarks of Skyworks Solutions, Inc., in the United States and other countries. Third-party brands and names are for identification purposes only, and are the property of their respective owners. Additional information, including relevant terms and conditions, posted at www.skyworksinc.com, are incorporated by reference.