

Silicon PNP Power Transistor

2SB755

DESCRIPTION

- Collector-Emitter Breakdown Voltage-
 $V_{(BR)CEO} = -150V(\text{Min})$
- Good Linearity of h_{FE}
- Complement to Type 2SD845

APPLICATIONS

- Designed for power amplifier applications.

ABSOLUTE MAXIMUM RATINGS($T_a=25^\circ\text{C}$)

SYMBOL	PARAMETER	VALUE	UNIT
V_{CBO}	Collector-Base Voltage	-150	V
V_{CEO}	Collector-Emitter Voltage	-150	V
V_{EBO}	Emitter-Base Voltage	-5	V
I_C	Collector Current-Continuous	-12	A
I_B	Base Current-Continuous	-1.2	A
P_C	Collector Power Dissipation @ $T_C=25^\circ\text{C}$	120	W
T_J	Junction Temperature	150	$^\circ\text{C}$
T_{stg}	Storage Temperature Range	-55~150	$^\circ\text{C}$

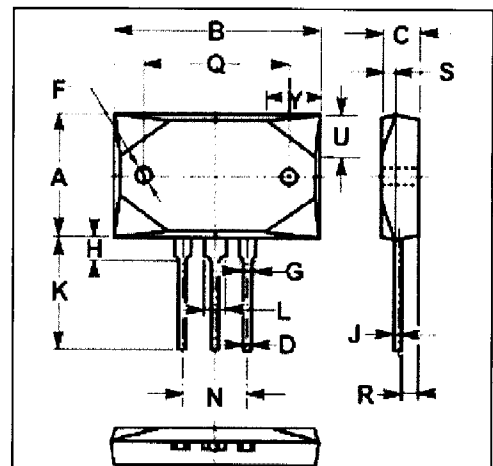
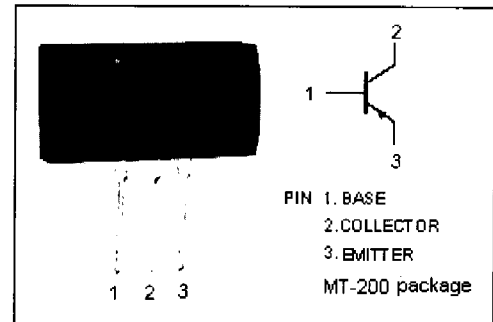

DIM	mm	
	MIN	MAX
A	21.00	21.70
B	35.80	36.70
C	5.60	6.20
D	1.04	1.07
F	3.10	3.50
G	1.90	2.40
H	3.60	4.00
J	0.55	0.85
K	20.00	20.80
L	2.90	3.40
N	10.50	11.10
Q	24.00	24.50
R	2.90	3.30
S	2.00	2.20
U	6.90	7.10
Y	8.90	9.10

NJ Semi-Conductors reserves the right to change test conditions, parameter limits and package dimensions without notice. Information furnished by NJ Semi-Conductors is believed to be both accurate and reliable at the time of going to press. However, NJ Semi-Conductors assumes no responsibility for any errors or omissions discovered in its use. NJ Semi-Conductors encourages customers to verify that datasheets are current before placing orders.

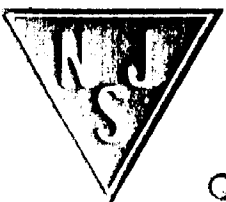

Silicon PNP Power Transistor

2SB755

ELECTRICAL CHARACTERISTICS

$T_C=25^\circ\text{C}$ unless otherwise specified

SYMBOL	PARAMETER	CONDITIONS	MIN	TYP.	MAX	UNIT
$V_{(BR)CEO}$	Collector-Emitter Breakdown Voltage	$I_C = -30\text{mA}; I_B = 0$	-150			V
$V_{(BR)EBO}$	Emitter-Base Breakdown Voltage	$I_E = -1\text{mA}; I_C = 0$	-5			V
$V_{CE(sat)}$	Collector-Emitter Saturation Voltage	$I_C = -5\text{A}; I_B = -0.5\text{A}$			-2.0	V
$V_{BE(on)}$	Base-Emitter On Voltage	$I_C = -5\text{A}; V_{CE} = -5\text{V}$			-1.5	V
I_{CBO}	Collector Cutoff Current	$V_{CB} = -150\text{V}; I_E = 0$			-50	μA
I_{EBO}	Emitter Cutoff Current	$V_{EB} = -5\text{V}; I_C = 0$			-50	μA
h_{FE}	DC Current Gain	$I_C = -1\text{A}; V_{CE} = -5\text{V}$	55		160	
C_{OB}	Output Capacitance	$I_E = 0; V_{CB} = -10\text{V}; f_{test} = 1.0\text{MHz}$		450		pF
f_T	Current-Gain—Bandwidth Product	$I_C = 1\text{A}; V_{CE} = -10\text{V}$		20		MHz

◆ h_{FE} Classifications

R	O
55-110	80-160